

Preface

Thank you for purchasing EM100 series mini inverter.

Document No.: 31010008

Version No.:103

Issue Date: 06/03/2013

EM100 mini inverter is a compact, intuitive, reliable and performing AC variable speed drive for 3-phase induction motors.

This manual offers the general information of installation, wiring, function parameters, daily maintenance, and fault diagnosis of EM100 mini inverter.

It is the duty of any user to perform the appropriate, correct installation or configuration of the optional parameters of the devices. Neither SINEE nor its distributors shall be responsible or liable for misuse of the information contained herein or mismatching the inverter with the motor.

In the interests of commitment to a policy of continuous development and improvement, SINEE reserves the right to update the specification of the product or its performance, or the content herein without notice.

More updates and information are available at www.sinee.cn.

CONTENTS

1. SAFETY INFORMATION	3
1.1 SAFETY PRECAUTIONS	3
1.2 PRECAUTIONS	6
2. OVERVIEW	7
2.1 VERIFYING PRODUCT	7
2.2 MODEL NUMBERING SCHEME AND NAMEPLATE	7
2.3 MODEL NUMBER	8
2.4 TECHNICAL SPECIFICATIONS	8
2.5 OUTLOOK	11
2.6 OVERALL AND INSTALLATION DIMENSIONS	12
3. INSTALLATION	14
3.1 MECHANICAL INSTALLATION	14
3.2 WIRING	23
4. KEYPAD OPERATION.....	38
4.1 KEYPAD	38
4.2 FUNCTION CODE CHECK AND EDITING METHOD	39
5. PARAMETER TABLES	43
5.1 FORMAT OF PARAMETER TABLES	43
5.2 PARAMETER TABLES	43
6. PARAMETER DESCRIPTION	59
7. TROUBLESHOOTING	102
7.1 FAULT AND CORRECTIVE ACTION	102
7.2 COMMON FAULT AND TROUBLESHOOTING	104
8. EMC(ELECTROMAGNETIC COMPATIBILITY).....	107
9. MAINTENANCE AND INSPECTION	110
9.1 MAINTENANCE AND INSPECTION.....	110
9.2 OUTLINE OF WARRANTY	111
APPENDIX A: EM100 MODBUS COMMUNICATION PROTOCOL.....	112
1. APPLICATION SCOPE.....	112
2. PHYSICAL INTERFACE.....	112
3. PROTOCOL FROMAT	112
4. EXPLANATION OF COMMAND	112
5. DESCRIPTION OF PROTOCOL FORMAT	114
6. EXAMPLE	117
APPENDIX B: ACCESSORIES.....	119

1. Safety Information



Danger: The addition of this symbol to a Danger or Warning safety label indicates that an electrical hazard exists, which will result in personal injury if the instructions are not followed.



Caution: This is the safety alert symbol. It is used to alert you to potential personal injury hazards. Obey all safety messages that follow this symbol to avoid possible injury or a risk of damage to the products or other devices.

1.1 Safety Precautions

Before Installation



Danger

1. Do not install the product if the package is with water, or component is missing or broken.
2. Do not install the product if the label on the package is not identical to that on the inverter.



Danger

1. Be careful of carrying or transportation. Risk of devices damage.
2. Do not use damaged product or the inverters missing component. Risk of injury.
3. Do not touch the parts of control system with bare hands. Risk of ESD hazard.

Installation:



Danger

1. Installation base shall be metal or other non-flammable material. Risk of fire.
2. Do not unscrew the fixing bolts, especially the bolts with red mark.



Caution

1. Do not leave cable strips or screws in the inverter. Risk of inverter damage.
2. Install the product at the place with less vibration and no direct sunlight.
3. Consider the installation space for cooling purpose when the inverter is installed in a cabinet.

Wiring:



Danger

1. Wiring must be performed by authorized and qualified personnel. Risk of danger.
2. Circuit-breaker should be installed between inverter and the mains. Risk of fire.
3. Be sure that the power supply is off before wiring, and ground inverter as per standard wiring. Risk of electrical hazard.
4. Grounding terminal must be grounded. Risk of electrical hazard and fire.
5. Dual keypad is not recommended. Risk of unexpected danger.



Caution

1. Never connect input power supply cable to output terminals U, V, and W of inverter. Pay attention to the terminal symbols, connect them correctly. Risk of inverter damage.
2. Be sure that the wiring meets EMC requirements and local safety standard. Cables should be in recommended sizes. Risk of accident.
3. Do not connect braking resistor to DC bus terminal $+$ & $-$. Risk of fire.
4. Tighten terminals with screw drivers of specified torque. Risk of fire.
5. Do not connect phase-shifting capacitor and LC/RC noise filter to output circuits.
6. Do not connect the solenoid switch and electromagnetic contactor to output circuits. Otherwise, it will trigger overcurrent protection, or damage inverter.
7. Do not disconnect internal wires of inverter. Risk of inverter damage.

Before Power-on



Caution

1. Verify that the input voltage is identical to the rated voltage of product, correct wiring of input terminals R, S, and T and output terminals U, V, and W, wiring of inverter and its peripheral circuits, and all wires should be in good connection. Risk of inverter damage.
2. Never perform voltage withstanding test on inverter, it has been done at ex-works. Risk of accident.



Danger

1. Inverter shall be power-on only after the front cover is assembled. Risk of electrical hazard.
2. Wiring of all peripherals should abide by the guide of this manual. Risk of accident.

After Power-on



Danger

1. Do not touch the inverter and its peripheral circuits with wet hands. Risk of electrical hazard.
2. Do not touch any input/output terminals of inverter with bare hands. Risk of electrical hazard.
3. After power is on at the first time, inverter will detect external circuit automatically. Meanwhile, do not touch wiring terminals U, V, and W of inverter, or wiring terminal of motor with bare hands. Risk of electrical hazard.



Danger

1. If autotuning is required, be careful of personal injury when motor is running. Risk of accident.
2. Do not change the defaults of parameters. Risk of devices damage.

During Operation



Danger

1. Do not touch cooling fans, heatsink or discharge resistor with bare hands. Risk of burning.
2. Non-professionals shall not detect signals during operation. Risk of personal injury or device damage.



Caution

1. Prevent any foreign items from being left in the devices during operation. Risk of device damage.
2. Do not control start/stop of inverter by ON/OFF of contactor. Risk of device damage.

Maintenance



Danger

1. Maintain and inspect devices after power is off. Risk of electric hazard.
2. Maintain and inspect inverter only after the voltage is lower than DC 36V between DC bus terminals $+$ & $-$, and power is off for 5 minutes. The residual charge on capacitor may cause personal injury.
3. Maintenance and inspection can only be performed by professionals. Risk of personal injury.
4. Parameter setting is required if inverter has been replaced. Plug-in & plug-out should be performed after power-off.

1.2 Precautions

■ **Motor Insulation Inspection**

When the motor is used for the first time or when the motor is reused after being kept, or when periodical inspection is performed, insulation inspection shall be conducted with motor so as to avoid damaging the inverter because of the insulation failure of the motor windings. The motor wires must be disconnected from the inverter during the insulation inspection. It is recommended to use the 500V megameter, and the insulating resistance measured shall be 5M Ω at least.

■ **Motor Thermal Protection**

If the motor rating does not match that of the inverter, especially when the rated power of the inverter is higher than that of the motor, adjust motor protection parameters in the inverter or install thermal relay to protect motor.

■ **Operating with the Frequency Higher than Grid Power Frequency**

Output frequency of EM100 is 0.00Hz ~ 320.00Hz. If EM100 is required to operate above 50.00Hz, please take the endurance of mechanical devices into consideration.

■ **Mechanical Vibrations**

Inverter may encounter mechanical resonance point of the load device at certain output frequencies which can be avoided by setting the skip frequency parameters of the inverter.

■ **Motor Heat and Noise**

Since output voltage of inverter is PWM wave and contains a certain amount of harmonics, so that the temperature, noise and vibration of the motor will be higher than those when the inverter runs at grid power frequency.

■ **Piezistor or the Capacitor Improving Power Factor on Output Side**

The inverter outputs PWM wave, do not install capacitor to improve power factor or piezistor for lightning protection on output side. Otherwise, it will trigger inverter instantaneous overcurrent or even damage inverter.

■ **Applied with the Rated Voltage**

Apply EM100 with the rated voltage. Failure to comply will damage inverter. If required, take a transformer to boost or step-down voltage.

■ **Do Not Apply a 3-Phase Input Inverter to 2-Phase Input Applications**

Do not apply a 3-phase input EM100 inverter to 2-phase input applications. Otherwise, it will result in faults or damage inverter.

■ **Lightning Protection**

EM100 has integrated lightning over-current protection device which has certain self-protection capacity against the lightning. Additional protection devices have to be installed between inverter and power supply in the area where lightning occurs frequently.

■ **Altitude Derating**

In altitudes above 1000m above sea level, the derating is required because of poor cooling effect due to rare air. Contact SINEE for technical support.

■ **Cautions for Inverter Disposal**

The electrolytic capacitors on the main circuit and PCBA may explode when they are burnt. Emission of toxic gas may be generated when the plastic parts are burnt. Please dispose inverter as industrial wastes.

2. Overview

2.1 Verifying Product



Caution

- Never install an inverter that is damaged or missing components. Otherwise, a risk of injury.

Refer to the following table, and check and verify the product.

Item	Action
If the products are identical to the purchase order.	Check the devices reference marked on the label.
Any part damaged.	Check the outlook if any damages.
Any screw loosened.	Check with a screwdriver if necessary.

2.2 Model Numbering Scheme and Nameplate

■ Model Numbering Scheme

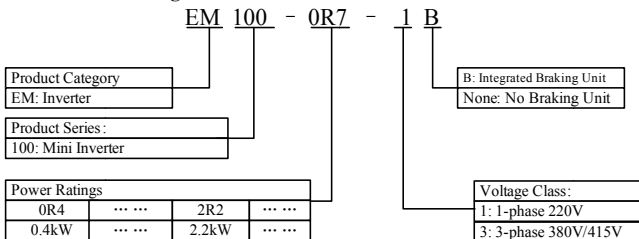

■ Nameplate

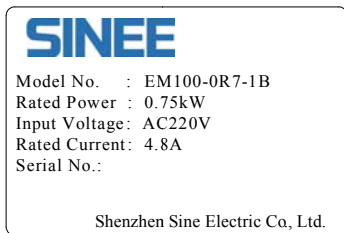

2.3 Model Number List

Table 2-1 EM100 Model Number List

Rated Input Voltage	Model No.	Motor Power(kW)	Rated Output Current(A)
1-phase AC220V	EM100-0R4-1B	0.4	2.8
	EM100-0R7-1B	0.75	4.8
	EM100-1R5-1B	1.5	8.0
	EM100-2R2-1B	2.2	10.0
3-phase AC380V/415V	EM100-0R7-3B	0.75	2.8
	EM100-1R5-3B	1.5	4.8
	EM100-2R2-3B	2.2	6.2
	EM100-4R0-3B	4.0	9.2
	EM100-5R5-3B	5.5	13
	EM100-7R5-3B	7.5	17
	EM100-011-3B	11	25
	EM100-015-3B	15	32

2.4 Technical Specifications

Table 2-2 EM100 Technical Specifications

Items		Specifications
Input		EM100-XXX-1B: 1-phase 220V ($\pm 20\%$) 50~60Hz ($\pm 5\%$) EM100-XXX-3B: 3-phase 380V/415V ($\pm 20\%$), 50~60Hz ($\pm 5\%$)
Output	Max. Output Voltage	3-phase, from 0 to U_{supply} .
	Rated Output Current	100% rated current non-stop output
	Max. Overload Current	150% rated current for 1 minute, 180% rated current for 10 seconds, 200% rated current for 2 seconds
Basic Control Function	Control Mode	V/F, SVC
	Speed Setting Mode	Speed setting mode, analog setting, RS485 Communication setting, terminal numeric setting, keypad setting.
	Running Mode	Keypad, control terminals (2-wire sequence, 3-wire sequence), RS485
	Frequency Control Range	0.00~320.00Hz
	Input Frequency Resolution	Numeric input: 0.01Hz Analog input: 0.10 Hz

User Manual
EM100 Mini Inverter

	Governor Deflection	1:50
	Speed Control Accuracy	1.0%
	Acceleration/ Deceleration Time	0.01~600.00 seconds
	V/F Features	Rated output voltage: 5%~100% adjustable Frequency base:20.00~320.00Hz adjustable
	Torque Boost	Automatic torque boost, fixed torque boost curve, customer defined V/F curve scaling
	Start Torque	150%/1Hz
	AVR	AVR is active while output voltage remains unchanged if input voltage is varying. Accuracy: $\pm 10V$ at rated input voltage
	Automatic Current Limit	Automatically limit output current, avoid frequent overcurrent trip
	DC Brake	Brake time:0~30S Brake current: 150% rated current
	Signal Input Source	Numeric, analog voltage, analog current, preset speed, simple PLC, Modbus communication, wobbbulation frequency, and PID. Primary frequency setting and auxiliary frequency setting integrated and terminal switch.
Input/ Output Function	Auxiliary Power Supply	10V/10mA , 24V/50mA
	Numeric Input Terminal	Internal electrical impedance: 27k Ω
		Acceptable external input:0~20V, the terminal is on at low level.
		Maximum input frequency: 1kHz
		6 numeric programmable input terminals, user can define terminal functions via function code.
Analog Input Terminals	1 voltage input:0~10V, and another input can be configured as a current input: 4~	

		20mA or a voltage input:0~10V
		Input impedance: voltage input: 1MΩ, current input: 250Ω
		Accuracy: 0.2%
	Numeric Output Terminal	1 programmable OC output Max. load capacity: 50mA/24V Output frequency range:0~1kHz
		1 programmable relay output, EA-NO, EB-NC, EC-Common port Contact capacity: 3A/AC250V Power factor:>0.4 or 1A/DC30V
Analog Output Terminal	1 programmable analog output terminal, output: 0~10V Max. load capacity: 2mA	
	Accuracy: 0.1V	
Display	LED	5-bit display, 8 input keys
Protection	Protections	Overcurrent, overvoltage, input/output phase loss, output short-circuit, overheating, and etc.
Application Conditions	Installation Site	Indoor, with altitude less than 1,000 meters, free from dust and corrosive gas, and direct sunlight
	Ambient Temperature	-10°C~+40°C. In the temperature range +40°C...+50°C, the rated output current is decreased by 1% for every additional 1°C. 20%~90%RH (no condensation)
	Vibration	< 0.5g
	Storage Temperature	-20°C~+65°C
	Installation Method	Wall mounting
Protection Grade		IP20
Cooling Method		Forced air cooling
Noise		38-62dB/A (See 3.1.4.3 for detail.)
Safety Standard		IEC61800-5-1:2007
EMC Standard		IEC61800-3: 2004

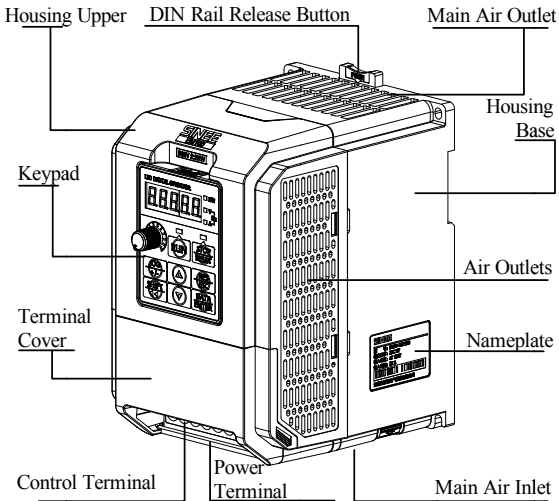

EM100 ID

2.6 Overall and Installation Dimensions

2.6.1 Overall Dimensions

Model No.	EM100-0R4-1B EM100-0R7-1B	EM100-1R5-1B EM100-2R2-1B EM100-0R7-3B EM100-1R5-3B EM100-2R2-3B EM100-4R0-3B	EM100-5R5-3B EM100-7R5-3B EM100-011-3B	EM100-015-3B
Unit (mm)				
W	95	110	130	150
W1	85	100	118	138
W2	11	11	/	/
H	152	163	220	289.5
H1	142	153	209	272
H2	159	170	/	/
H3	130.5	140.5	/	/
H4	110.5	121.5	/	/
D	117	132	152.5	173
D1	130	145	165.2	185.7
D2	74	84	104.7	125
d1	4.5	4.5	5.5	5.5
d2	4.5	5	/	/
N.W./Kg	1	1.5	2.8	5.0
Frame	SIZE1	SIZE2	SIZE3	SIZE4

Remarks:

D2: The distance between the entrance hole of power cable and the installation plate.
Symbol / indicates that the size is not available.

2.6.2 Diagram of Overall and Installation Dimensions

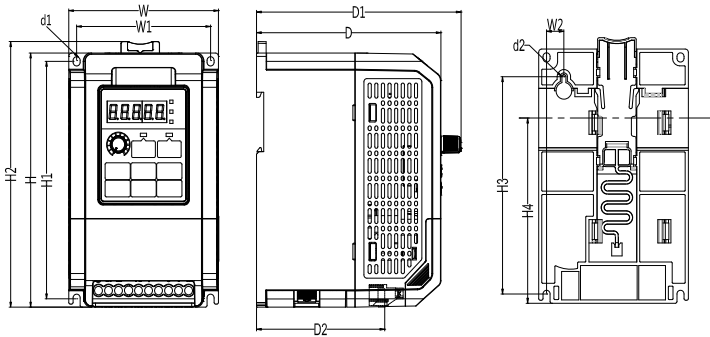

2.6.3 Keypad Dimensions

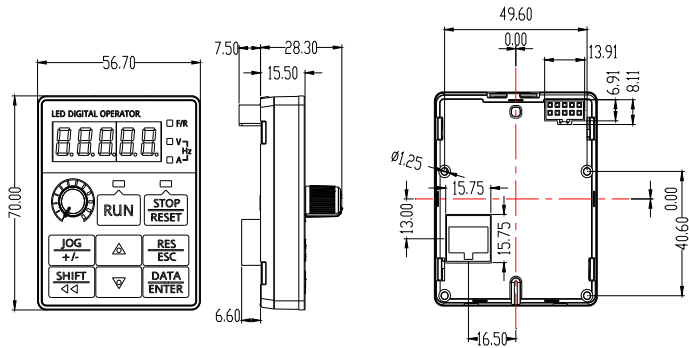

2.6.4 Dimensions of Keypad Chassis (Accessories) and Mounting Holes

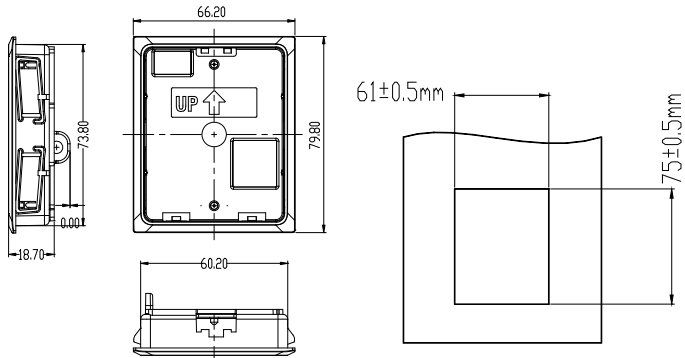

Remarks: Please contact distributors or SINEE for keypad chassis if needed.

3. Installation

3.1 Mechanical Installation

3.1.1 Installation Recommendations



Caution

- 1. Always hold the case when carrying the inverter.**
Risk of injury if only holding the terminal cover.
- 2. Installation base shall be metal or other non-flammable material.**
Risk of fire if installing the inverter on inflammable materials.
- 3. Install a cooling fan when installing inverter in a cabinet, and air temperature shall be lower than 40°C at air inlet.**
Overheating may result in fire or other accidents.

3.1.2 Installation Site

Considerations for installation site:

- Good ventilation indoor
- Ambient temperature: -10°C~+40°C, 20%~90%RH(No condensation)
- No high temperature and high moisture, humidity: <90%RH, no water drops or any other liquid drops
- Never install on flammable materials
- No direct sunlight
- No flammable, corrosive gas or liquid
- No dust, floating fiber or metal particles
- Firm and steady installation base

3.1.3 Precautions

Take protective measures during installation to prevent foreign matters like metal particles or dust from entering the inverter when drilling. Please take off the protective objects after installation.

3.1.4 Installation Direction, Space and Cooling

A fan is integrated in EM100 for forced air cooling. EM100 has to be installed vertically for the purpose of good cooling circulation. Sufficient spaces have to be left between EM100 and its peripheral objects. Multi-EM100 can be installed in parallel horizontally and vertically. See followings for specific space requirement, heat dissipating capacity and mass airflow.

3.1.4.1 Installation Space of Single EM100

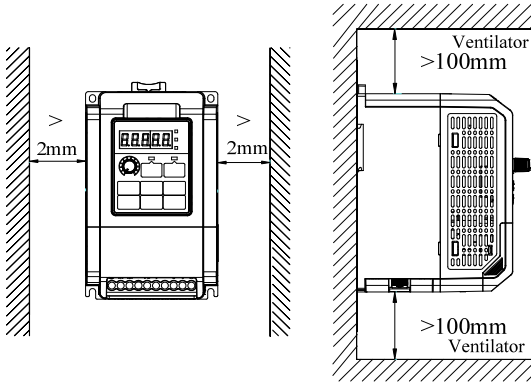

3.1.4.2 Vertical Installation of Multi-EM100

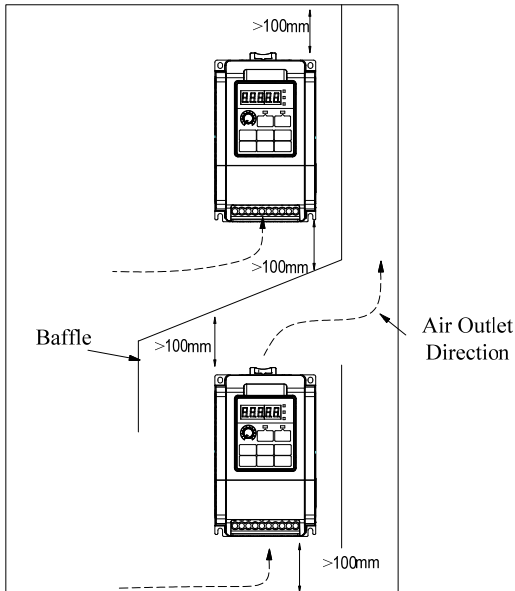

3.1.4.3 Table of Heat Dissipating Capacity (HDC), Mass Airflow(MAF) and Noise of Single EM100

Model No.	Frame	MAF (CFM)	MAF (m ³ /h)	HDC (W)	Noise (dB/A)
EM100-0R4-1B	SIZE1	8	13.6	42	38
EM100-0R7-1B		8	13.6	70	38
EM100-1R5-1B	SIZE2	13	22	90	40
EM100-2R2-1B		13	22	120	40
EM100-0R7-3B		13	22	75	40
EM100-1R5-3B		13	22	85	40
EM100-2R2-3B		13	22	105	40
EM100-4R0-3B		13	22	150	40
EM100-5R5-3B	SIZE3	31.2	53	174	45
EM100-7R5-3B		31.2	53	252	45
EM100-011-3B		31.2	53	362	45
EM100-015-3B	SIZE4	106	180	520	55

Remarks:

1. The values listed in the table refer to that the HDC and the MAF required when single EM100 is mounted in an enclosed space.
2. The HDC is calculated based on the rated voltage, rated current and preset carrier frequency of each model.
3. If multi-EM100 has to be installed in an enclosed space, please add HDC and MAF.

3.1.4.4 Load Shedding Curve

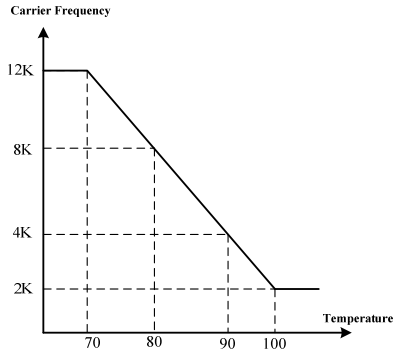

3.1.5 Installing with Screws

a. 4-hole Installation

See *Overall and Installation Dimensions* for the dimensions of 4-hole (Hole a). Refer to Figure a, and punch 4 holes on the installation panel. Put the inverter against the panel and mate 4 holes, and then tighten screws in the 4 holes (Tighten any of the 2 screws in diagonal position, tighten 4 holes with screws for strengthened installation. Screw size: M4xL, L>12mm, tightening torque: 1N.m±10%)

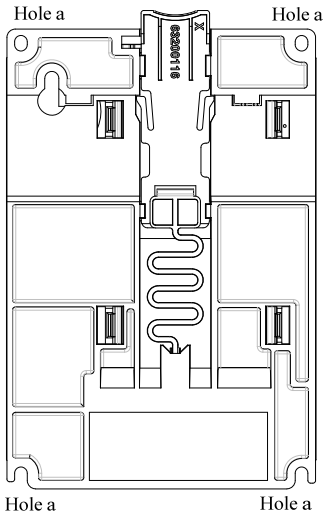

Figure a

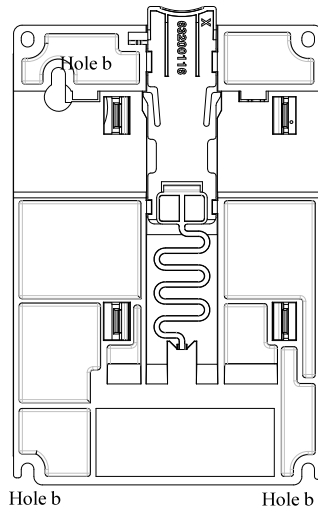

Figure b



Do not take the sunk screws as shown in the picture. Otherwise, inverter may be damaged.



Take screws combined with springs and plain gaskets to install inverter.

b. 3-hole Installation

See *Overall and Installation Dimensions* for the dimensions of 3-hole (Hole b). Refer to Figure b, and punch 3 holes on the installation panel with screws in each of them. Do not tighten the screws, leave a distance of 7.5~9mm between the gaskets and installation panel, hung the inverter onto the 3 screws from top to bottom (Screw size: M4xL, L>16mm, tightening torque: 1N.m±10%), and then tighten the 2 screws at the bottom.

3.1.6 DIN Rail Installation (DIN Rail Width: 35mm)

See *Overall and Installation Dimensions* for the dimensions of DIN rail. Refer to the following Figure, install and remove the inverter by pushing the DIN rail release button.

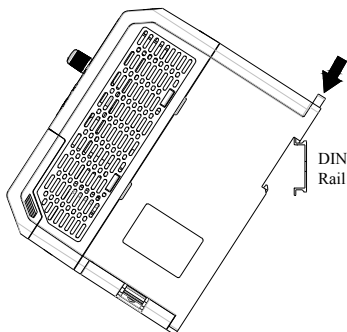

Mount multi-inverter in parallel with DIN rail:

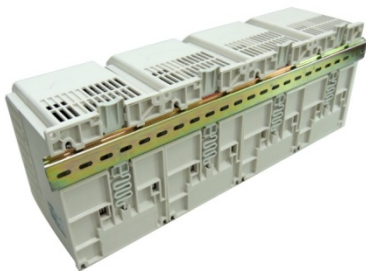

3.1.7 Flange Mounting (For the Models with Frame SIZE3&4)

Unit (mm) Frame	W	L	W1	W2	W3	L1	L2	L3	d	H1	H2
	SIZE3	138	223	170	157	37	261	249	99	5.5	84
SIZE4	156	290	190	177	37	329	317	142	5.5	131	70
Remarks	Size of mounting hole									Size of depth	

Remarks:

Instruction of assembling the flange: Assemble the flange left and right on the left and right sides of EM100 first, fasten the screws on the top and at the bottom, locate the inverter with flange into the mounting hole, and tighten the screws to finish the assembly.

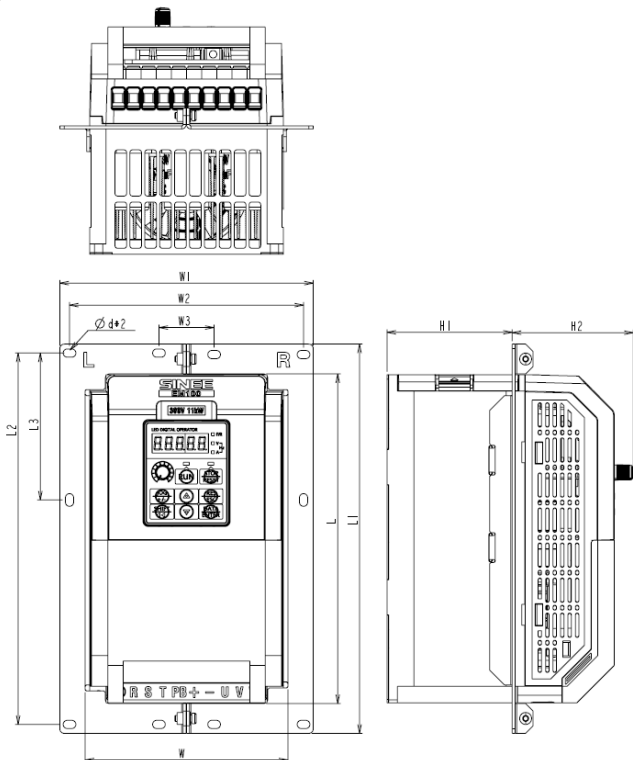

3.1.8 Disassembly and Assembly of Keypad

a. Disassemble keypad. See following Figure: Push the buckle on the keypad in Direction 1 first, and then lift up the keypad in Direction 2.

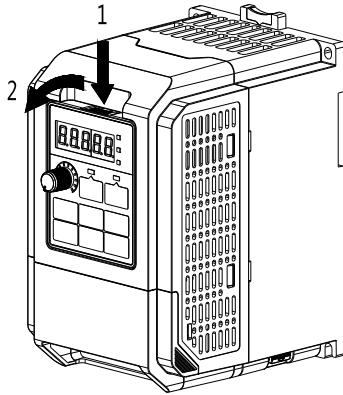

b. Assemble keypad. See following Figure: Place keypad in the slot in Direction 1, and then press the keypad in Direction 2 until it clicks into right place.

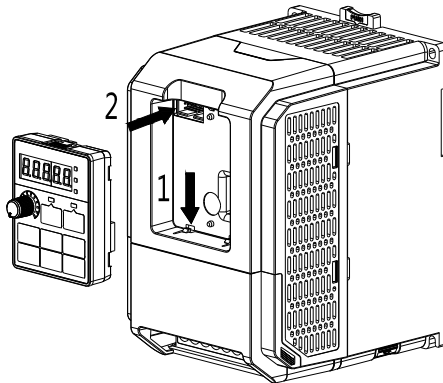

3.1.9 Disassembly and Assembly of Terminal Cover

a. Disassemble terminal cover: remove terminal cover in the direction as shown in the Figure below.

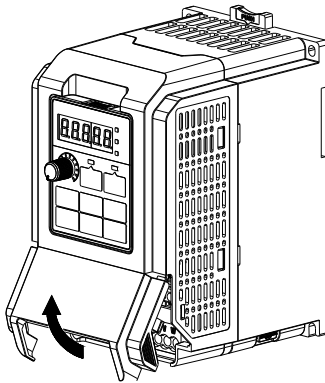

b. Assemble keypad. See following Figure: Place the upper buckle of the terminal cover in the slot of upper housing in Direction 1, and then press the two lower buckle of terminal cover in Direction 2 until it clicks into right place of upper housing.

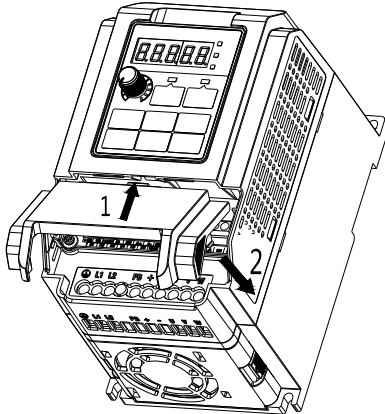

3.1.10 Mounting Keypad

a. Surface mounting: Punch 4 holes ($3.5 \pm 0.4 \text{ mm}$) as per the overall dimensions of keypad, tighten the keypad on the installation panel with M3 tapping screw (For plastic materials, tightening torque: $0.5 \text{ N.m} \pm 10\%$, the maximum tightening depth in keypad: $11 \pm 1 \text{ mm}$)

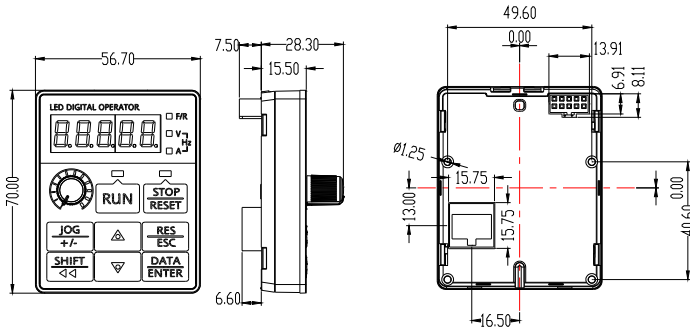

b. Flush mounting: See 2.8 for chassis (Accessories) dimensions. Punch a square hole on the installation panel, press the chassis into the panel, and mount the keypad on the chassis referring to the following Figure. Disassemble keypad by pressing keypad buckle with a slotted screwdriver on the back of the panel (Refer to A in the Figure).

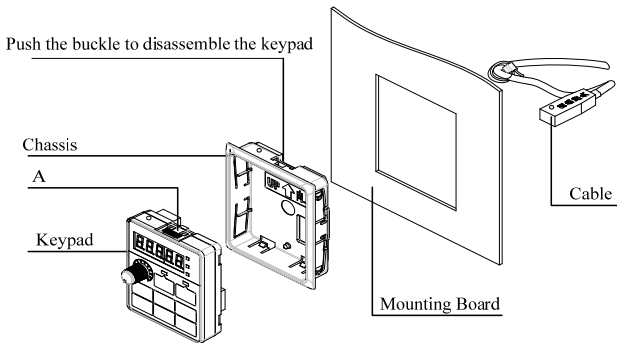



3.2 Wiring

Open the terminal cover, check the terminal block, main circuit and control circuit terminals.

Considerations for wiring:

- Main circuit terminals R/L1, S/L2, and T/L3 are input terminals. Misconnection will result in inverter damage. Furthermore, check if the power supply is within the rated voltage and rated current listed on the nameplate.
- Ground the grounding terminals to avoid electric shock or fire, and to lower noise interference.
- Tighten the screws between terminal and its cable in case of sparkle caused by loose screws.
- Do not connect control terminal before power-off.

 <p>Danger</p>	<ol style="list-style-type: none">1. Always turn off the input power supply before wiring. Risk of electric shock or fire.2. Wiring must be performed by authorized and qualified personnel. Risk of electric shock or fire.3. Be sure that the ground terminals are earthed. Risk of electric shock or fire.4. Always verify the function of emergency stop terminal in work after connecting. Risk of injury. (User shall take the responsibilities of wiring).5. Never touch the input or output terminals directly with bare hands, or connect the terminals of inverter to the housing, or connect the input terminals to output terminals. Risk of electric shock or short circuit may occur.
 <p>Caution</p>	<ol style="list-style-type: none">1. Always confirm if the voltage of AC input power supply matches the rated voltage of inverter. Risk of injury or fire.2. Never perform voltage withstanding test. Otherwise, semi-conductors and other devices can be damaged.3. Connect braking resistor or braking unit according to required wiring. Risk of fire.4. Tighten terminals with screw drivers of specified torque. Risk of fire.5. Never connect input power supply cable to output terminals U, V, and W. Misconnection will result in inverter damage.6. Do not connect phase-shifting capacitor and LC/RC noise filter to output circuits. Otherwise, the interior parts of inverter will be damaged.7. Do not connect the switch and contactor to output circuits. When inverter is running with load, surge current and surge voltage, which are generated by the operation of switch or contactor, will damage inverter.8. Do not disconnect the internal wires of inverter. Otherwise, the inverter will be damaged.

3.2.1 Connection to Peripherals

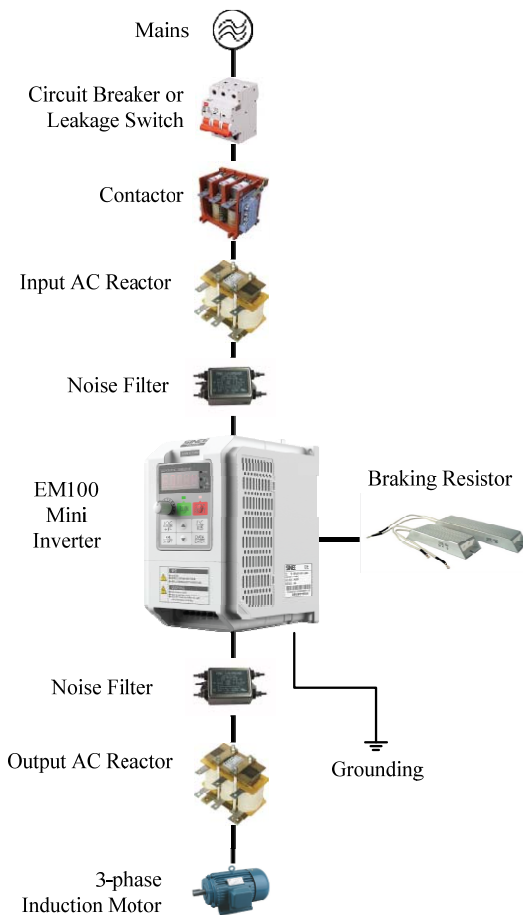

Figure 3-1 Connections between EM100 and Its Peripherals

3.2.2 Wiring Main Circuit and Control Circuit

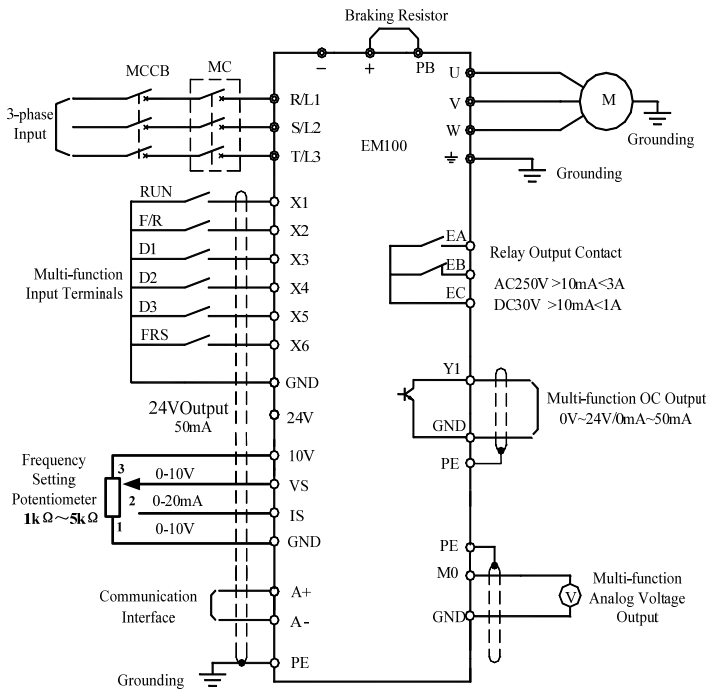

Figure 3-2 Wiring Main Circuit and Control Circuit

Remarks:

1. ⊙ refers to main circuit terminals. ○ refers to control circuit terminals.
2. User selects braking resistor based on real needs.
3. Signal cable and power cable should be separated. Try to cross control cable and power cable in 90° if needed.

3.2.3 Function of Main Circuit



Danger

1. Wiring only after the power supply is OFF. Risk of electric shock.
2. Only professionals shall conduct wiring. Risk of devices damage or personal injury.
3. Be sure that the grounding terminal is earthed. Risk of electric shock and fire.



Caution

1. The rating of input power supply shall be the same as the rated values of inverter.
Risk of inverter damage.
2. Motor shall be applicable to the inverter.
Risk of motor damage or inverter trips protection.
3. Do not connect power supply to U, V, and W terminal of inverter.
Risk of inverter damage.
4. Do not connect braking resistor to DC bus terminal + and -. Risk of fire.

See Figure 3-3 for EM100 main circuit terminals.

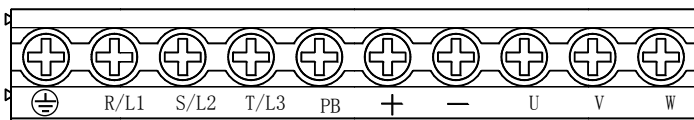

Figure 3-3-1 Main Circuit Terminal Block of EM100 ≤ 11kW

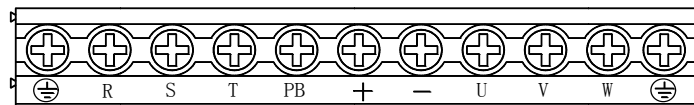

Figure 3-3-2 Main Circuit Terminal Block of EM100 ≥ 11kW

Table 3-1 Function of EM100 Main Circuit Terminals

Terminal	Function
R/L1, S/L2, T/L3	AC power input terminals for connecting to 3-phase AC380V/415V power supply. (For 1-phase AC220V input inverter: Terminal R/L1, and S/L2 are for connecting 1-phase AC220V input, do not connect T/L3.)
U, V, W	AC output terminals of inverter for connecting to 3-phase induction motor.
+, -	Positive and negative terminals of internal DC bus.
PB	Connecting terminals of braking resistor. One end connected to + and the other to PB.
	Grounding terminal

Remarks: No phase sequence requirements on wiring of the input side of inverter.

3.2.4 Standard Wiring of Main Circuit

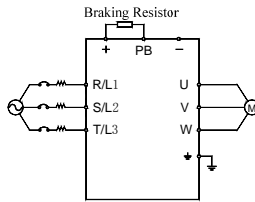

Figure 3-5 Standard Wiring of EM100 Main Circuit

3.2.5 Wiring Main Circuit on Input Side

■ Installing a Circuit Breaker

Install an air circuit breaker (MCCB) between the power supply and input terminals.

- Choose a MCCB with a capacity of 1.5-2 times of inverter rated current.
- The time features of MCCB should meet that of overheating protection of inverter (150% rated current /1 minute).
- If single MCCB is shared by two or more inverters or other devices, the contact of fault output relay shall be connected to power contactor coil, so that the power supply will be turned off by the fault signals, as shown in Figure 3-6.

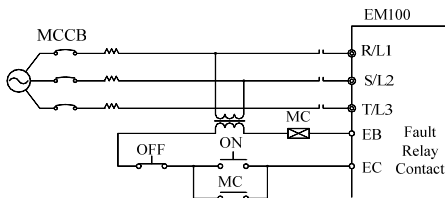

Figure 3-6 Connecting to Input Circuit Breaker

■ Installing a Leakage Circuit Breaker

High frequency leakage current is generated by high frequency PWM signal output of inverter. Select a special purpose leakage breaker with a trigger current $\geq 30\text{mA}$. For a regular leakage breaker, the trigger current: $\geq 200\text{mA}$ and the active time at 0.1S or above.

■ Installing an Electromagnetic Contactor

Install an electromagnetic contactor which is applicable to inverter power as shown in Figure 3-6.

- Start/stop of the inverter can be controlled by the electromagnetic contactor on input side. Inverter may break down if the electromagnetic contactor is on and off frequently. The operation interval between start and stop of the inverter shall ≥ 30 minutes, if electromagnetic contactor on input side must be used for controlling.
- The inverter will not automatically start if power is on after failure.

■ Connecting to the Terminal Block

Power input phase sequence is not related to the phase sequence of terminals R, S, and T on the terminal block, any two of them can be connected connected randomly.

■ Installing an AC Reactor

If power supply is connected to capacitive load, an excessive big surge current will occur and rectifier of inverter can be broken down. Install an optional 3-phase/1-phase AC reactor on input side of inverter to suppress peak current and voltage, and improve power factor of the system.

■ Installing a Surge Absorber

Install a surge absorber for inductive loads (electromagnetic contactors, solenoid valves, solenoid coils, or electromagnetic circuit breakers) nearby the inverter.

■ Countermeasure for Excessively Large Leakage Current(Only Applicable to the products of SIZE3&SIZE4)

When the inverter is applied to the applications which are sensitive to leakage current, for instance: civil application, malfunction of leakage protection switch is likely to occur. Please loosen the screw anticlockwise on EMC terminal.

■ Installing a Noise Filter on Power Supply Side

To filter noise transmitted between power cable and the inverter, and the impact on power grid caused by the noise produced by the inverter.

- A special purpose noise filter is required for the inverter.
- Correct vs incorrect installations of noise filters as shown in Figure 3-7 and Figure 3-8.

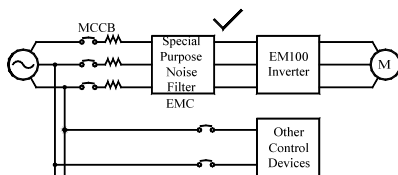

Figure 3-7 Correct Installation of Noise Filter

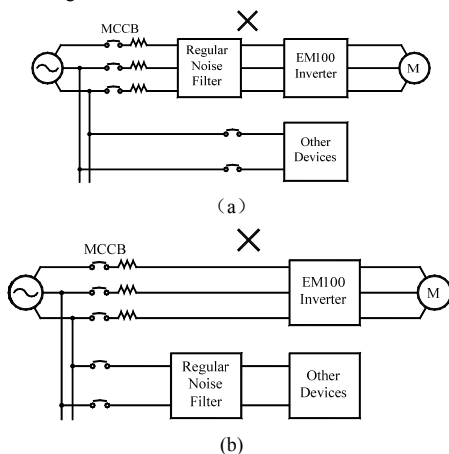

Figure 3-8 Incorrect Installation of Noise Filter

3.2.6 Wiring the Output Side of Main Circuit

■ Connecting the Inverter to Motor

Connect inverter output terminals U, V, and W to motor input terminals U, V and W. Check that the motor forwards with the Forward Command. Switch any 2 of the inverter output terminals U, V, or W to each other and reconnect if the motor reverses.

■ Never Connecting Power Supply Cable to Output Terminals

Never connect power supply cable to output terminals. If power is input to the output terminals, the inverter would be damaged.

■ Never Short-Circuit or Grounding Output Terminals

Never touch output terminals directly with bare hands, or connect the output cable to the housing of inverter. Otherwise, an electric shock and short-circuit may occur. Furthermore, do not short-circuit the output cable.

■ Never Using a Phase-shifting Capacitor

Never connect phase-shifting electrolytic capacitor or LC/RC filter to the output circuit. Otherwise, inverter will be damaged.

■ Never Using an Electromagnetic Switch

Never connect electromagnetic switch or electromagnetic contactor to the output circuit. Otherwise, failure to comply will cause overcurrent or overvoltage protection. Sometimes inverter will be damaged.

■ Installing a Noise Filter on the Output Side

Install a noise filter on the output side of inverter to reduce inductive interference and radio interference.

- Inductive interference: Electromagnetic induction generates noise on the signal line which may cause the control device malfunctions.
- Radio interference: The high frequency electromagnetic waves generated by inverter and cable cause radio devices nearby to make noise when receiving signals.

See Figure 3-9 for installing a noise filter on the output side.

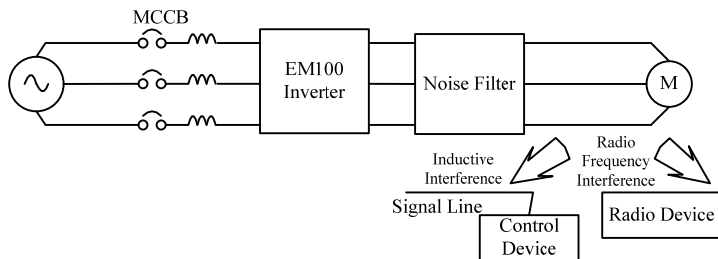

Figure 3-9 Installing a Noise Filter on the Output Side

■ Countermeasures Against Inductive Interference

As stated previously, except installing a noise filter, all output cables can be routed through a grounded metal pipe to prevent inductive interference on the output side. The distance between output cables and signal line should $> 30\text{cm}$, and the inductive interference will be reduced considerably, as shown in Figure 3-10.

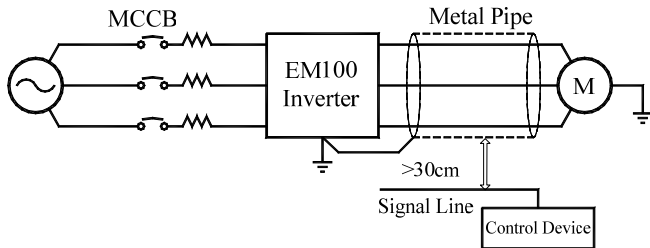

Figure 3-10 Countermeasures Against Inductive Interference

■ Countermeasures Against Radio Frequency Interference(RFI)

RFI will be generated from the inverter as well as the input cable and the output cable. Install noise filters on both input and output sides, and shield inverter with an iron case to reduce RFI. As shown in Figure 3-11.

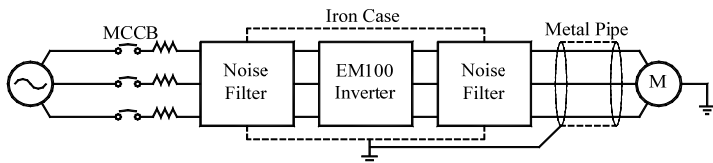

Figure 3-11 Countermeasures Against RFI

■ Cable Length Between Inverter and Motor

The longer cable between the inverter and motor is, the higher carrier frequency is, and the greater high-frequency harmonic leakage current on its cable is. All of which will affect inverter and its peripherals. See Table 3-2 to adjust carrier frequency for reducing the high-frequency harmonic leakage current.

When motor cable $> 50\text{m}$, connect a special 3-phase AC reactor of the same capacity as that of the inverter to the output terminals.

Table 3-2 Cable Length and Carrier Frequency Between Inverter and Motor

Cable Length	$< 50\text{m}$	$< 100\text{m}$	$> 100\text{m}$
Carrier Frequency	$< 10\text{kHz}$	$< 8\text{kHz}$	$< 5\text{kHz}$
F00.17 Function Parameter	10.000	8.000	5.000

3.2.7 Main Circuit Cable

Table 3-3 Cable Size and Screw Specifications

Model No. of Inverter	Terminal									Screw	Tightening Torque (N.m)	Cable Size (mm ²)	Cable Type
	L1	L2		PB	+	-	U	V	W				
EM100-0R4-1B	L1	L2		PB	+	-	U	V	W	M3	1.0~1.2	1.5	300V
EM100-0R7-1B	L1	L2		PB	+	-	U	V	W	M3	1.0~1.2	1.5	
EM100-1R5-1B	R/L1	S/L2		PB	+	-	U	V	W	M3	1.0~1.2	4	
EM100-2R2-1B	R/L1	S/L2		PB	+	-	U	V	W	M3	1.0~1.2	4	
EM100-0R7-3B	R/L1	S/L2	T/L3	PB	+	-	U	V	W	M3	1.0~1.2	1.5	750V
EM100-1R5-3B	R/L1	S/L2	T/L3	PB	+	-	U	V	W	M3	1.0~1.2	2.5	
EM100-2R2-3B	R/L1	S/L2	T/L3	PB	+	-	U	V	W	M3	1.0~1.2	4	
EM100-4R0-3B	R/L1	S/L2	T/L3	PB	+	-	U	V	W	M3	1.0~1.2	4	
EM100-5R5-3B	R	S	T	PB	+	-	U	V	W	M4	1.2~1.4	6	
EM100-7R5-3B	R	S	T	PB	+	-	U	V	W	M4	1.2~1.4	6	
EM100-011-3B	R	S	T	PB	+	-	U	V	W	M4	1.2~1.4	6	
EM100-015-3B	R	S	T	PB	+	-	U	V	W	M4	1.2~1.4	10	

Remarks:

1. Take the voltage drop into consideration for selecting cable. Generally the voltage drop should be $< 5V$ and calculated according to following formula:

$$\text{Voltage drop} = \sqrt{3} * \text{Cable resistance ratio } (\Omega/\text{km}) * \text{Cable length (m)} * \text{Rated current (A)} * 10^{-3}$$

2. If placed in plastic slot, the cable should be uprated by one level.
3. The cable should be connected to the applicable cable and wiring terminal.
4. The size of grounding cable should be the same as that of power cable.

3.2.8 Grounding Wiring

- Make sure that the ground terminal \oplus is grounded.
- Do not share the grounding cable with welding machine or power devices.
- The size of grounding cable should meet the technical standard of electrical appliances, and the distance to grounding point should be as short as possible.
- Do not form the grounding cable as a circuit whenever two or more inverters are used synchronously. See Figure 3-12 for the correct and incorrect grounding wirings.

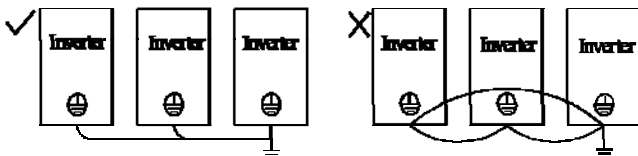

Figure 3-12 Grounding Wiring

3.2.9 Wiring Braking Resistor

Install a braking resistor in EM100 for quick brake of motor, and set the corresponding function code of inverter as dynamic braking active. Connect braking resistor to terminal +, PB, do not connect to other terminals. See Figure 3-13 for braking resistor installation.

See the Appendix B for braking resistor selection.

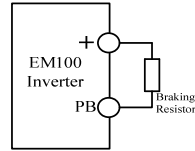

Figure 3-13 Wiring Braking Resistor

3.2.10 Wiring Control Circuit Terminals

3.2.10.1 Control Circuit Terminals

The control circuit terminals of EM100 are located on the control PCBA:

- Analog input terminals: Voltage input signals VS. Current input signals IS.
- Numeric input terminals: X1, X2, X3, X4, X5, X6
- Numeric output terminals: EA, EB, EC, Y1
- Analog output terminal: M0
- Auxiliary power supply terminals: 10V, GND
- RS485 communication interface: A+, A-
- GND is the signal common port of VS, IS, X1, X2, X3, X4, X5, X6, M0, Y1

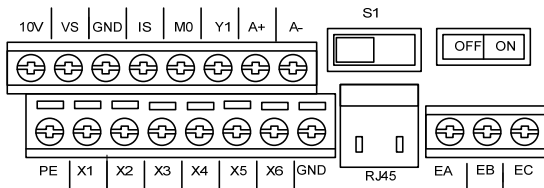



Figure 3-14 Control Circuit Terminal Block

3.2.10.2 Function of Control Circuit Terminals

Table 3-4 Function of Control Circuit Terminals

Mode	Terminal	Terminal Name	Terminal Function
Analog Input	+24V	Power Supply for External Devices	24V power supply for external devices. Max. output current: 50mA
	+10V	Power supply for analog terminal	10V power supply to external devices, max. output current: 10mA. It is generally used as the power supply for external potentiometer. Potentiometer resistance range: 1kΩ~5kΩ

User Manual
EM100 Mini Inverter

	VS	VS Analog voltage input	0/2~10V, input impedance: 1MΩ Max. input voltage:15V
	GND	Common port	Input/output signal common port
	IS	IS Analog current /voltage input	IS can be configured as current input or voltage input and switched by S2. Input range:0/4~20mA or 0/2~10V
Analog Output	M0	Analog output terminal M0	0~10V, output accuracy: ±2%, Max. output current: 2mA, Impedance allowed: >10kΩ
Multi-function Numeric Output	Y1	OC output terminal	Programmable multi-function output terminals as shown in F03.00
Communication	A+	RS485	RS485 A+
	A-	Communication interface terminal	RS485 A-
Numeric Input	X1	Multi-function input terminal	Program the relevant terminals by setting F02.00 ~ F02.05 to achieve the input control of setting function
	X2		
	X3		
	X4		
	X5		
	X6		
	GND	Common port	Common port for input/output signal
SPI Communication	RJ45	External keypad terminal	For connecting external operator
Relay Output	EA	Relay output terminal	EA-EC: NO EB-EC: NC
	EB		
	EC		
Jumper Switch	S1	Selecting resistor applicable to RS485 terminal	Jumper switch for selecting resistor which is applicable to RS485 terminal  OFF: No terminal resistor ON: With terminal resistor Default is no terminal resistor
	S2	IS Voltage/Current Input Option	Jumper switch for setting IS as voltage input or current input  OFF: Current input ON: Voltage input Default is set as current input.

3.2.10.3 Wiring the Analog Input Terminals

See Figure 3-15 for wiring terminals VS via analog voltage signal:

When analog voltage input signal is as the external power supply, see Figure 3-15-a for wiring terminal VS. When analog voltage input signal is as the potentiometer, wire terminal VS as shown in Figure 3-15-b.

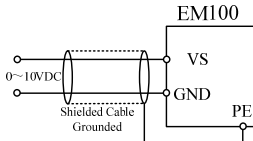

Figure 3-15-a

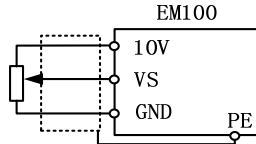

Figure 3-15-b

Figure 3-15 Wiring Terminal VS

See Figure 3-16 for wiring terminals IS via analog current signal:

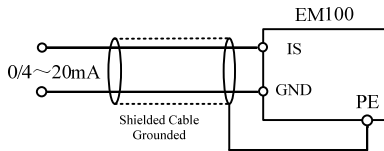

Figure 3-16 Wiring IS Terminal

3.2.10.4 Wiring Multi-function Input Terminals

Refer to the Figure 3-17 for wiring EM100 multi-function input terminals.

3.2.10.5 Wiring Multi-function Output Terminal

Multi-function output terminal Y1 outputs monitoring signals in OC mode. For instance, the frequency reach signal in the operation. Details refer to F03.00, F03.01 multi-function output terminal function options. See Figure 3-18 for wiring of OC output terminal.

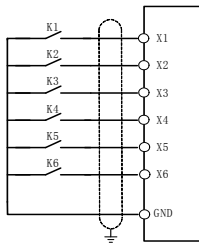

Figure 3-17 Wiring Multi-function Input Terminal

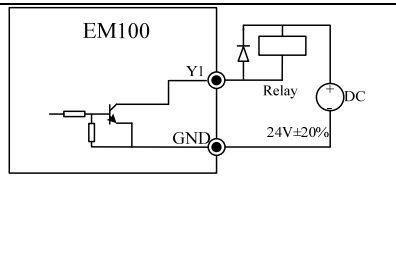

Figure 3-18 Wiring Multi-function Output Terminal with External Power Supply

Remarks: When connecting to inductive components (Like relay coil), connect fly-wheel diode in anti-parallel.

3.2.10.6 Wiring Communication Terminal

1. Refer to the Figure 3-19 for connecting single inverter to PC/PLC:

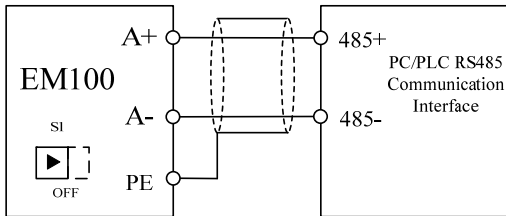

Figure 3-19 RS485 and Single Inverter Connection

2. Refer to the Figure below for connecting multi-inverter to PC/PLC:

When PLC communicates with multi-inverter, connect the RS485 Communication interface A+ of inverters to A+, A- to A-. Only switch S1 ON (S1 switch is the terminal resistor of the inverter on the far end), start internal 120Ω terminal resistor. See Figure 3-20 for connecting multi-inverter to PC/PLC:

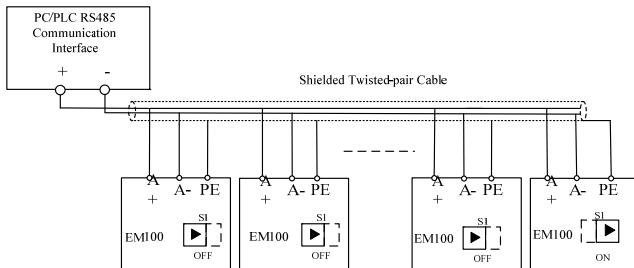

Figure 3-20 RS485 and Multi-inverter Connection

3. Refer to the Figure 3-21 for connecting inverter to PC/PLC via RS485/RS232 converter

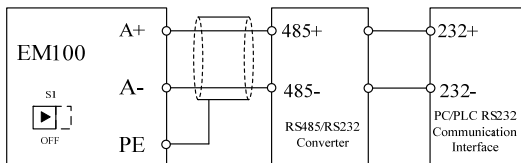

Figure 3-21 Connecting Inverter to PC/PLC via RS485/RS232 Converter

Remarks:

For the applications with serious electromagnetic noise, please ground GND of each communication point together.

3.2.10.7 Size of Control Circuit Cable and Screw

To lower interference and attenuation of control signal, the cable length of control signal should be in a maximum of 50m, and the distance should be in a minimum of 30cm between the signal cable and the power cable. Shielded twisted-pair cable shall be used when inputting analog signal externally.

Table 3-5 Control Circuit Terminal and Cable Size

Terminal	Screw Size	Tightening Torque (N.m)	Cable Diameter (mm ²)	Cable Type
VS,IS,X1,X2,X3,X4,X5,X6,EA,EB,EC,Y1,M0,10V,A+,A-	M3	0.5~0.8	0.5~1.25	Shielded Stranded
GND	M3	0.5~0.8	0.5~2.0	Cable

Remarks:

- Install with a PH0 cross-head screwdriver.
- Take pin terminal or cable strip length by 5~7mm for connection.
- Only after the terminal screw is fully loosened anticlockwise first, the cable can be inserted.

Remarks for wiring control circuit:

- If wiring is correct.
- Separate the control circuit cable from the other cables.
- Separate the cable of control circuit terminals EA, EB, EC, and Y1 from the cables of other control circuit terminals.
- Use shielded twisted-pair cables for control circuit to avoid malfunctions. The wiring distance should be in a maximum of 50m. Wrap the shield net with insulating tape to prevent the shield net from contacting with other signal cables and housing of device.

3.2.10.8 Extending Keypad Cable

1. RJ45 keypad interface and regular network cable extension (Interface abides by EIA/TIA568B standard)

2. See Figure 3-22 for wiring.

- Dual keypad is not recommended. Otherwise, risks of unexpected danger may occur.
- Take the wiring mode for ease of installation.
- Keypad cable extension should be in a maximum of 3m.
- Extension can be as long as 15m if a CAT5 or a better cable used and under applicable electromagnetic environment.

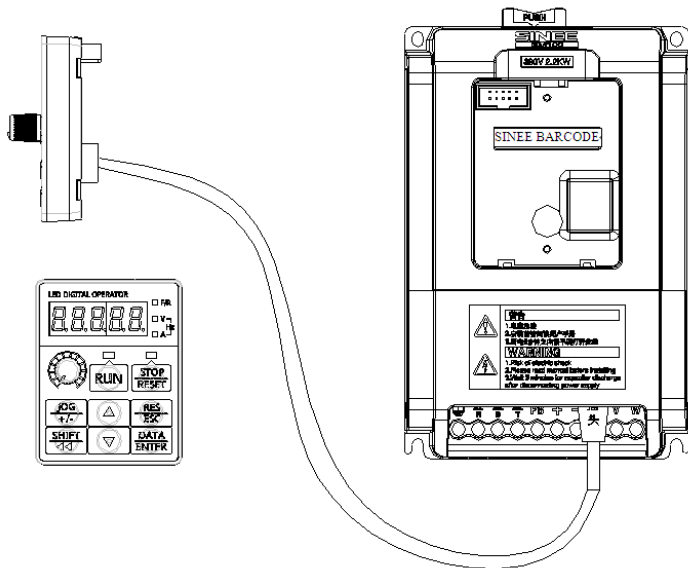

Figure 3-22 Disassembling the Keypad and Connecting Extension Keypad Wire

3.2.10.9 Wiring Check

Perform the following checks after completing wiring:

- If wiring is correct.
- If anything is left in inverter like screw, or wire clippings.
- If the screw is loose.
- If the wire strip on one terminal connects to other terminals.

4. Keypad Operation

4.1 Keypad

EM100 keypad consists of LED display, keys, and potentiometer. See Figure 4-1. User can perform function setting, status monitoring, fault monitoring, start/stop control, and jog operation for EM100 through keypad.

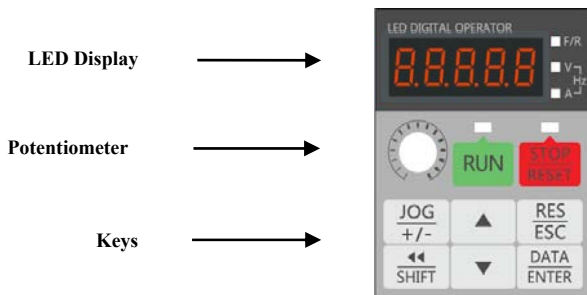













Figure 4-1 LED Keypad

Table 4-1 Name and Function of Each Key on the Keypad

Part	Name	Function
	Left SHIFT	Shift the bit of parameters when editing parameters. Shortcut key for selecting the monitoring parameter in operation
	RESET/ESCAPE	Reset previous status. Escape from editing the present parameter.
	Key for Multi-functional programming	For programmable JOG or forward/reverse input function selection
	ENTER	Save edited parameter of present function parameter. For entering sub-menu.
	RUN	In keypad control mode, press the key to start inverter.
	STOP/RESET	In keypad control mode, press the key to stop inverter. Reset setting status from fault status.
	LED Display	Display function setting, running monitoring, fault monitoring codes and parameters.
	UP	Select function code, menu or increase the setting value of parameter.

	DOWN	Select function code, menu or reduce the setting value of parameter.
	Status Indicator	<p>RUN: Green On: the inverter is running. Flashing: the inverter is stopping.</p> <p>STOP: Red On: the inverter fails.</p> <p>F/R: Red Off: Forward On: Reverse</p> <p>A:Red Present display data unit is A. V:Red Present display data unit is V.</p> <p>A and V are on simultaneously if the unit is Hz. A and V are off if displaying other units.</p>
	Keypad Potentiometer	Regulate speed as per analog value.

4.2 Function Code Check and Editing Method

There are 5 keypad operation modes of EM100: function setting, operation monitoring, fault monitoring, jog operation, and start/stop. See Table 4-2 for keypad operation modes and the functions.

Table 4-2 Keypad Operation Modes

Keypad Operation Mode	Key Function
Function Setting	<ol style="list-style-type: none"> 1. Display, edit, save, reset and lock the function code and its parameters. 2. Reset default of the parameters. 3. Edit relevant parameter when the inverter is running.
Operation Monitoring	Monitor C00.00-C00.17 parameters when the inverter is running.
Fault Monitoring	<ol style="list-style-type: none"> 1. Output frequency, DC bus voltage, and output current when fault occurs. 2. The last 3 faults.
Jog Operation	In setting status, press JOG key, the inverter runs as per the jog numeric frequency. Release the JOG key, the inverter stops.
Start/Stop	Press RUN and then release in keypad start/stop mode, inverter starts to run. Press STOP/RESET button in operation status, inverter stops.

Function setting, operation monitoring and fault monitoring are operated by menu setting. Start/stop, jog operation and keypad numeric potentiometer are operated by single key.

4.2.1 Main Menu Selection

3 main menu operation options: Function setting, operation monitoring, and fault monitoring. Function setting menu F00.__ __ , F01.__ __ , F02.__ __ , F03.__ __ , F04.__ __ , F05.__ __ , F06.__ __ , F07.__ __ , F08.__ __ , F09.__ __ , F10.__ __ , F11.__ __ , operation monitoring menu C00.__ __ , fault monitoring menu E00.__ __ . Selecting main menus refers to the following method:

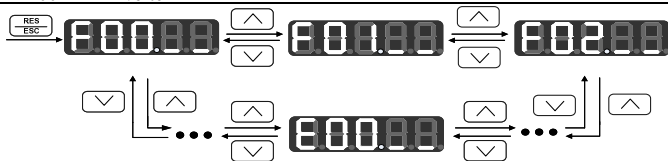

Figure 4-2 Main Menu Selection

4.2.2 Sub-menu Selection

Select 1 code in sub-menu selection. For instance, in sub-menu of F01. __ __, select any code from F01.00~F01.22. See Figure 4-3 for selecting code.

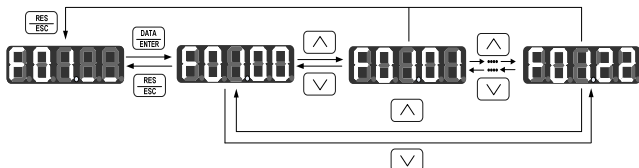

Figure 4-3 Sub-menu Selection

4.2.3 Function Setting

Inverter can display, edit, save and reset parameter in function setting status. Set parameter correctly before operation starts.

Selecting Parameter to View Value

- Select corresponding function code and view its parameter via selecting main menu and sub-menu. For instance: follow the operation procedures shown in Figure 4-4 to view parameter of F02.05.

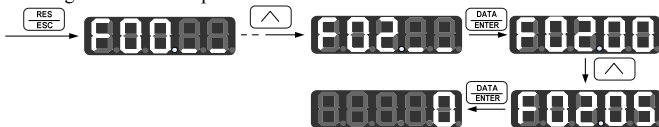





Figure 4-4 Procedures for Viewing Parameter

Editing Parameter

- Follow the viewing procedures to enter the function code first, and then editing the parameter refers to the procedures shown in Figure 4-5.
- No matter it is in function setting status or operation status, after entering parameter editing status, LSB(on the right) flashing refers to that editing the parameter is permitted. If LSB does not flash, it indicates that editing the parameter is prohibited.
- Save and reset parameter.
- Press **DATA/ENTER** to save the edited parameter, and -END- display refers to that the parameter is saved. Press **DATA/ENTER** to return previous menu for next code.

- If there is an unexpected editing, press , and then LSB (on the right) flashing refers to that the parameter is reset previous value. Press  again to return previous menu and do not edit parameter, but press , the edited parameter will be saved.
- Take F00.03 for instance, its original parameter value is 0, save or reset the parameter as per the procedures shown in Figure 4-5.

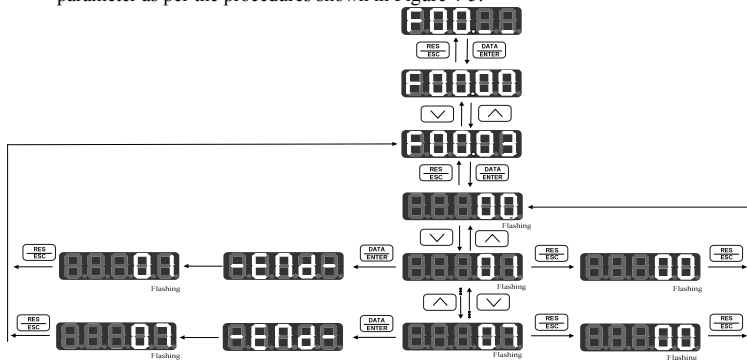

Figure 4-5 Parameter Saving and Resetting Procedures

4.2.4 Operation Status Monitoring

Enter operation monitoring code when inverter starts, and monitor the operational status of inverter in real-time. Select a code from C00.00 ~C00.17 in operational monitoring sub-menu, view and monitor its parameter. For instance, see Figure 4-6 for procedures to view code C00.01 (Actual value of output voltage) when inverter is running.





Figure 4-6 Procedures of Viewing and Editing Operation Monitoring Parameters

4.2.5 Keypad Potentiometer

If the speed setting mode of inverter is in VP keypad potentiometer setting mode, when F00.03=1, adjust setting frequency value by adjusting keypad potentiometer.

4.2.6 Shortcut Key Operation

When inverter is in operation or stop status, press , monitoring display value displays in a cycle with output frequency (C00.00) ->Output voltage(C00.01)->Output current(C00.02), ->DC bus voltage(C00.05).

When inverter is in operation or stop status, and keypad display is on the sub-menu of monitoring code group, press  or , the keypad will display setting value of

F00.07 (primary numeric frequency) which will assist user to edit setting frequency. If there is no operation with keypad for 5 seconds, keypad display will return the sub-menu of monitoring code group.

Edit setting frequency by press Δ or ∇ in operation status or stop status.

4.2.7 Fault Reset/Monitoring

Select a code from E00.00~E00.05 to view its parameter value on sub-menu of fault monitoring. For instance, see Figure 4-7 for the procedures to view E00.02 parameter. Referring to Figure 4-7, press Δ or ∇ in fault monitoring status to view each fault status, and switch to fault code to view the last 3 faults status by pressing DATA ENTER .

After clearing fault, press STOP RESET to reset parameter setting status from fault status.

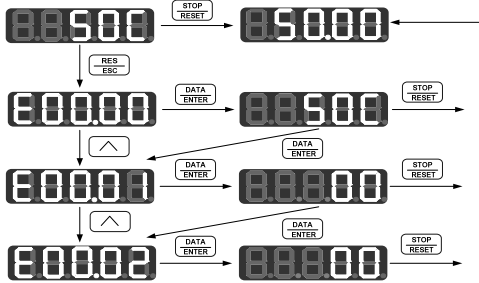

Figure 4-7 Procedures of Viewing Fault Monitoring Parameters

4.2.8 Function of JOG Key

When F06.15=1, inverter runs as per setting jog frequency when pressing $\text{JOG } \pm / -$, and will stop immediately when releasing $\text{JOG } \pm / -$.

When F06.15=2, inverter will switch running direction forward with reverse once when pressing $\text{JOG } \pm / -$. F/R indicator on the keypad: OFF refers to forward, ON refers to reverse.

4.2.9 Start/Stop

If F00.02 ones place=0, start/stop of inverter is in keypad control mode. Inverter starts when pressing RUN . In operation status, inverter will stop immediately when pressing STOP RESET .

4.2.10 Insufficient Operation Conditions

When soft-start relay is off and pressing RUN or $\text{JOG } \pm / -$ (when $\text{JOG } \pm / -$ function is jog running), the keypad displays P.OFF for 1 second, and inverter does not run and output. After the operation conditions can meet requirements, inverter will run when giving operation command again.

4.2.11 Autotuning Motor Parameter via Keypad Operation

After setting F01.13=1(Stationary Autotuning) or F01.13=2(Rotational Autotuning), press DATA ENTER and confirm, keypad displays rUN, then press RUN to start autotuning motor parameters. Keypad displays StUdy in the process of autotuning, F01.13=0 after autotuning finished.

5. Parameter Tables

5.1 Format of Parameter Tables

14 groups of parameters of EM100: F00, F01, F02, F03, F04, F05, F06, F07, F08, F09, F10, F11, C00, and E00. F00-F11: function setting codes, C00 group: monitoring codes, and E00 group: fault monitoring codes.

Items in the Table	Description
Number	Function code. For instance:F00.00
Function	Name of the code, explanation of code function.
Range	Parameter setting list and range
Unit and Abbreviation	HOUR-Hour, min-Minute, S-Second, mS- Millisecond, %- Percentage (Rated value). rpm- Revolutions per minute , V-Voltage, A- Ampere, °C-degree Celsius, kW- Kilowatt, mH- Millihenry, Ω-Ohm, Hz- Herz , kHz- Kiloherz , bps- Bits per second ,Hz/S- Herz per second. SQRT- Square root, MAX-Maximum, MIN-Minimum.
Default	Setting value after resetting defaults of function codes (F00.22)
Type	<ul style="list-style-type: none"> ●: The parameter editing is permitted when the inverter is running. ○: The parameter editing is prohibited when the inverter is running. X : The parameter is read only.

5.2 Parameter Tables

No.	Function	Range	Unit	Default	Type
F00 Group: General Parameters					
F00.00	Speed Reference Input Monitoring	Frequency:0.00~Fmax	Hz	XXXXX	X
F00.01	Drive Control Mode	0:V/F (Open loop control) 1:SVC		1	○
F00.02	Start/Stop Control Mode Options	Ones place: Start/Stop control mode options 0: Inverter keypad 1: Terminal 2: Communication Tens place: Terminal control mode options 0:RUN-Run,		00	○

User Manual
EM100 Mini Inverter

		F/R-Forward/Reverse 1: RUN-Forward, F/R- Reverse 2: RUN-NO forward, Xi-NC stop, F/R-NO reverse 3: RUN-NO run, Xi-NC stop, F/R- Forward/Reverse			
F00.03	Primary Speed Setting Mode	0: Primary numeric frequency setting 1: VP keypad potentiometer 2: VS analog voltage input terminal 3: IS analog current input terminal		1	○
F00.04	Auxiliary Speed Setting Mode	0: Auxiliary numeric frequency setting 1: VP keypad potentiometer 2: VS analog voltage input terminal 3: IS analog current input terminal 4~9: Not Used 10: Process PID 11: Program operation 12: Wobulation control		0	○
F00.05	Integrated Speed Setting Mode	0: Primary speed setting 1: Auxiliary speed setting 2: Primary speed setting + Auxiliary speed setting 3: Primary speed setting - Auxiliary speed setting 4: MAX { Primary speed setting, Auxiliary speed setting } 5: MIN { Primary Speed Setting, Auxiliary speed setting }		0	○
F00.06	Analog Integrated Speed Setting Mode	0: Integrated speed setting 1: VS* Integrated speed setting 2: IS* Integrated speed setting		0	○
F00.07	Primary Numeric Frequency Setting	0.00~Fmax	Hz	0.00	●

User Manual
EM100 Mini Inverter

F00.08	Auxiliary Numeric Frequency Setting	0.00~Fmax	Hz	0.00	●
F00.09	Acceleration Time 1	0.01~600.00	S	15.00	●
F00.10	Deceleration Time1	0.01~600.00	S	15.00	●
F00.11	Maximum Frequency	Fmax:20.00~320.00	Hz	50.00	○
F00.12	Upper Limit Frequency	Fup: Fdown~Fmax	Hz	50.00	○
F00.13	Lower Limit Frequency	Fdown: 0.00~Fup	Hz	0.00	○
F00.14	Motor Running Direction	0: Forward 1: Reverse		0	●
F00.15	Reverse Control	0: Reverse permitted 1: Reverse prohibited		0	○
F00.16	F/R Deadband	0.00~600.00	S	0.00	○
F00.17	Carrier Frequency	2.000~12.000	kHz	4.000	●
F00.18	Random Carrier Mode	0: Fixed carrier 1: Random carrier 2: Fixed carrier, which can be adjusted by carrier temperature and carrier current. 3: Random carrier, which can be adjusted by carrier temperature and carrier current.		2	●
F00.19	Upper Carrier Frequency	2.000~12.000	kHz	8.000	●
F00.20	Lower Carrier Frequency	2.000~12.000	kHz	2.000	●
F00.21	Saving Setting Frequency Options	0: Do not save the frequency before power loss 1: Save the frequency before power loss		0	○
F00.22	Default Reset	0:Disabled 1:Reset default		0	○

F01Group: Motor Parameters					
F01.00	Motor Rated Power	0.40~655.35	kW	XXXX	○
F01.01	Motor Rated Voltage	60~480	V	XXX	○
F01.02	Motor Rated Current	0.1~100.0	A	XXXXX	○
F01.03	Motor Rated Frequency	20.00~320.00	Hz	XXXXX	○

User Manual
EM100 Mini Inverter

F01.04	Motor Rate Speed	1~20000	rpm	XXXXX	○
F01.05	Motor Wiring Mode	0: Y Wiring 1: Δ Wiring		X	○
F01.06	Motor Rated Power Factor	0.70~0.95		XXX	○
F01.07	Motor Efficiency	70.00~97.00	%	XXXXX	○
F01.08	Idling Excitation Current	0.1~100.0	A	XXXXX	○
F01.09	Stator Resistance R1	0.01~300.00	Ω	XXXXX	○
F01.10	Rotor Resistance R2	0.01~300.00	Ω	XXXXX	○
F01.11	Stator& Rotor Mutual Inductance Lm	0.1~3000.0	mH	XXXXX	○
F01.12	Leakage Inductance Coefficient	0.001~1.000		XXXXX	○
F01.13	Autotuning Parameters	0:No autotuning 1:Stationary autotuning 2: Rotational autotuning		0	○

F02 Group: Input Terminal Parameters					
F02.00	Multi-function Input X1-RUN	0: No function		1	○
F02.01	Multi-function Input X2-F/R	1: RUN-Run 2: F/R Forward/Reverse		2	○
F02.02	Multi-function Input X3-D1	3: Preset Speed Terminal 1 4: Preset Speed Terminal 2		3	○
F02.03	Multi-function Input X4-D2	5: Preset Speed Terminal 3 6: Terminal for switching acceleration/deceleration time		4	○
F02.04	Multi-function Input X5-D3	1&2 7: Coast-to-stop		5	○
F02.05	Multi-function Input X6-FRS	8: FRS Inverter fault reset 9: FJOG Forward jog 10: RJOG Reverse jog 11: Terminal UP 12: Terminal DOWN 13: UP/DOWN Clearing 14: Acceleration/Deceleration prohibited 15: 3-wire sequence run/stop control(Pulse stop) 16: DC brake input command at stop		8	○

		17: Switch run command to terminal 18: Program running reset 19: Switch to auxiliary speed setting 20: External fault input 21: Start wobulation operation																				
F02.06	Multi-function Input Positive/Negative Logic	<table border="1"> <tr> <td>X</td><td>X</td><td>X</td><td>X</td><td>X</td><td>X</td> </tr> <tr> <td>6</td><td>5</td><td>4</td><td>3</td><td>2</td><td>1</td> </tr> <tr> <td>0</td><td>0</td><td>0</td><td>0</td><td>0</td><td>0</td> </tr> </table>	X	X	X	X	X	X	6	5	4	3	2	1	0	0	0	0	0	0	000000	○
		X	X	X	X	X	X															
6	5	4	3	2	1																	
0	0	0	0	0	0																	
<p>0: Positive Logic Terminals are on at 0V/off at 24V</p> <p>1: Negative Logic Terminals are off at 0V/on at 24V</p> <p>X1 is LSB, arrange in logical order, the 7th and the 8th bits are not used.</p>																						
F02.07	Multi-function Input Filter Times	0~100		10	○																	
F02.08	X1 Input Delay Time	0.00~300.00	S	0.00	○																	
F02.09	X2 Input Delay Time	0.00~300.00	S	0.00	○																	
F02.10	VP Filter Time	0.00~10.00	S	0.10	●																	
F02.11	VP Input Voltage Corresponding to 0.00Hz Frequency	0.0~100.0	%	1.0	●																	
F02.12	VP Input Voltage Corresponding to MAX. Frequency	0.0~100.0	%	98.0	●																	
F02.13	VS Filter Time	0.00~10.00	S	0.10	●																	
F02.14	IS Filter Time	0.00~10.00	S	0.10	●																	
F02.15	VS Output Bias 0	-100.0~100.0	%	0.0	●																	
F02.16	VS Output Bias 1	-100.0~100.0	%	25.0	●																	
F02.17	VS Output Bias 2	-100.0~100.0	%	75.0	●																	
F02.18	VS Output Bias 3	-100.0~100.0	%	100.0	●																	
F02.19	VS Input Bias 0	0.0~VS Input Bias 1	%	0.0	●																	
F02.20	VS Input Bias 1	VS Input Bias 0~ VS Input Bias 2	%	25.0	●																	

User Manual
EM100 Mini Inverter

F02.21	VS Input Bias 2	VS Input Bias 1~ VS Input Bias 3	%	75.0	●
F02.22	VS Input Bias 3	VS Input Bias 2~100.0	%	100.0	●
F02.23	IS Output Bias 0	-100.0~100.0	%	0.0	●
F02.24	IS Output Bias 1	-100.0~100.0	%	25.0	●
F02.25	IS Output Bias 2	-100.0~100.0	%	75.0	●
F02.26	IS Output Bias 3	-100.0~100.0	%	100.0	●
F02.27	IS Input Bias 0	0.0~IS Input Bias 1	%	20.0	●
F02.28	IS Input Bias 1	IS Input Bias 0~ IS Input Bias 2	%	40.0	●
F02.29	IS Input Bias 2	IS Input Bias 1~ IS Input Bias 3	%	80.0	●
F02.30	IS Input Bias 3	IS Input Bias 2~100.0	%	100.0	●

F03 Group: Output Terminal Parameter					
F03.00	Multi-function Output Y1	0: Inverter is running 1: Frequency reach signal(FAR) 2: Output Frequency range detection (FDT) 3: Reverse running 4: Frequency reached upper limit 5: Frequency reached lower limit 6: Inverter fault 7: Inverter is ready to work 8: Overheating prealarm		0	○
F03.01	Relay Output R1			6	○
F03.02	Analog Output M0	0: Output frequency 1: Input command frequency 2: Output current 3: Output voltage 4: VS 5: IS 6: +10V (2mA MAX.) 7: DC bus voltage		0	○
F03.03	M0 Output Lower Limit	0.00~100.00	%	0.00	●
F03.04	M0 Output Upper Limit	0.00~100.00	%	100.00	●
F03.05	M0 Output Gain	0.00~300.00	%	100.00	●

F04 Group: Start/Stop Control Parameters					
F04.00	DC Brake Current at Start	0.00~150.00	%	0.0	○
F04.01	DC Brake Time at Start	0.00~30.00	S	0.00	○
F04.02	Acceleration/ Deceleration Mode	0: Linear mode 1: S curve mode		0	○
F04.03	S Curve Time	0.00~600.00	S	0.00	○
F04.04	Not Used				
F04.05	Stop Mode Options	0: Ramp-to-stop 1: Coast-to-stop		0	○
F04.06	DC Brake Start Frequency at Stop	0.10~60.00	Hz	2.00	○
F04.07	DC Brake Current at Stop	0.00~150.00	%	0.00	○
F04.08	DC Brake Waiting Time	0.00~30.00	S	0.00	○
F04.09	DC Brake Time at Stop	0.00~30.00	S	0.00	○

F05 Group: V/F Control Parameters					
F05.00	V/F Curve Scaling	0: Automatic torque boost 1~10: Fixed torque boost curve 11~20: Oil pump motor boost curve 21~30: Synchronous motor boost curve 31~34: Blower/water pump boost curve 35: Customer defined V/F curve scaling		35	●
F05.01	Frequency Base	Fbase: 20.00~320.00	Hz	50.00	○
F05.02	Voltage 1	0.00~100.00	%	1.00	●
F05.03	Voltage 2	0.00~100.00	%	4.00	●
F05.04	Voltage 3	0.00~100.00	%	10.00	●
F05.05	Voltage 4	0.00~100.00 Ue=100.0%	%	16.00	●

User Manual
EM100 Mini Inverter

F05.06	Frequency 1	0.00~Frequency 2 Fbase=100.0%	%	1.00	●
F05.07	Frequency 2	Frequency 1~ Frequency 3	%	4.00	●
F05.08	Frequency 3	Frequency 2~ Frequency 4	%	10.00	●
F05.09	Frequency 4	Frequency 3~100.00	%	16.00	●
F05.10	Open Loop Slip Compensation	0.00~200.00	%	150.00	●
F05.11	Stator Voltage drop Compensation Gain	0.00~100.00	%	80.00	●
F05.12	Excitation Boost Gain	0.00~300.00	%	180.00	●
F05.13	Oscillation Suppression	0.00~100.00	%	0.00	●
F05.14	Overmodulation Level	1.00~1.10		1.00	●
F05.15	AVR	0: Disabled 1: Enabled 2: AVR is disabled if the DC bus voltage > the rated voltage of DC bus, and it will be enabled if the DC bus voltage ≤ the rated voltage of DC bus.		0	○

F06 Group: Auxiliary Function Parameters					
F06.00	Jog Numeric Frequency	0.00~Fmax	Hz	5.00	●
F06.01	Jog Acceleration Time	0.01~600.00	S	15.00	●
F06.02	Jog Deceleration Time	0.01~600.00	S	15.00	●
F06.03	Acceleration 2	0.01~600.00	S	15.00	●
F06.04	Deceleration 2	0.01~600.00	S	15.00	●
F06.05	UP/DOWN Frequency Rate	0.00~100.00 Unit:Hz/200mS 0.00(Autorate integration)		1.00	●
F06.06	Frequency Reach Signal FAR	0.00~20.00	Hz	5.00	●
F06.07	FDT Increasing Threshold	0.00~Fmax	Hz	30.00	○
F06.08	FDT Decreasing Threshold	0.00~Fmax	Hz	30.00	○

User Manual
EM100 Mini Inverter

F06.09	Output Voltage	5.00~100.00	%	100.00	●
F06.10	Dynamic Brake Control	0: Disabled 1: Enabled 2: Enabled at running 3: Enabled at deceleration		1	○
F06.11	Dynamic Brake Voltage	380V:510~800 220V:300~400	V	700 380	○
F06.12	Brake Duty Ratio	5.0~100.00	%	100.00	○
F06.13	Fan Control	0: Run at power-on 1: Smart mode		1	○
F06.14	Not used				
F06.15	JOG Key Function Setting	0: Disabled 1: Jog running function 2: F/R switching function		1	○
F06.16	Function of STOP Key	0: Enabled in keypad start/stop mode 1: Enabled in all start/stop modes 2: Enabled in keypad start/stop mode, external fault trips in other modes		0	○
F06.17	Customer Defined Scaling	0.01~200.00		30.00	●
F06.18	Wobulation Operation Mode	Ones place: Wobulation operation control 0: Auto-operation (After preset wobulation time is up, wobulation starts.) 1: Terminal Control (After preset wobulation time is up, the terminal is on.) Tens place: Wobulation input mode 0: Wobulation operation started after reaching the mid-point 【(Wobulation upper limit + wobulation lower limit)/2】 1: Wobulation operation starts when its preset time is up		00	○
F06.19	Preset Wobulation Frequency	0.00~Fmax	Hz	0.00	●
F06.20	Preset Wobulation Time	0.00~600.00	S	15.00	●
F06.21	Upper Limit Frequency of Wobulation	0.00~Fmax	Hz	40.00	●
F06.22	Lower Limit Frequency of Wobulation	0.00~Fmax	Hz	20.00	●

User Manual
EM100 Mini Inverter

F06.23	Jump Frequency of Wobulation	0.00~Fmax	Hz	5.00	●
F06.24	Rising Time of Wobulation	0.00~600.00	S	15.00	●
F06.25	Dropping Time of Wobulation	0.00~600.00	S	5.00	●
F06.26	Lower Limit Frequency Control	0: Run as per lower limit frequency 1: Run at zero speed when lower limit frequency running time is up.		0	○
F06.27	Lower Limit Frequency Running Time	0.00~600.00	S	60.00	○
F06.28	Monitoring Code Options of Run/Stop Status	0: C00.00 1: C00.01 16: C00.16 17~99: Not Used 100: No change in keypad operation		0	○

F07 Group: Fault and Protection Function Parameters					
F07.00	Current Limit Control	0: Current limit disabled 1: Current limit mode 1 2: Current limit mode 2		1	○
F07.01	Current Limit	50.00~180.00	%	150.00	●
F07.02	Frequency Decreasing Time (Limit Current in Constant Speed Operation)	0.00~600.00 Mode 1&2	S	5.00	●
F07.03	Current Limit Mode 2 Proportion Gain	0.01~10.00		0.30	●
F07.04	Current Limit Mode 2 Integral Time	0.00~300.00 0.00 Integration Disabled	S	10.00	●
F07.05	Overvoltage Stall Control	0: Overvoltage stall disabled 1: Overvoltage stall mode 1 2: Overvoltage stall mode 2		1	○
F07.06	Overvoltage Stall Voltage	380V:640~800 220V: 370~400	V	750 390	●
F07.07	Overvoltage Stall Mode 2 Proportion Gain	0.01~10.00		0.30	●

User Manual
EM100 Mini Inverter

F07.08	Overvoltage Stall Mode 2 Integral Time	0.00~300.00 0.00: Integration Disabled	S	10.00	●			
F07.09	Overheating Prealarm Temperature	50~115	℃	85	○			
F07.10	Motor Overload Protection Options	0: Prohibited 1: Permitted		1	○			
F07.11	Motor Overload Protection Time	30~300	S	60	○			
F07.12	Fault Retry Control	Ones place: Fault retry times 0: Fault retry prohibited 1~3: Fault retry for 1, 2, and 3 times 4: Unlimited fault retry Tens place: In the process of fault retry, fault output terminals: 0: Off 1: On		00	○			
F07.13	Fault Retry Timelag	0.01~30.00	S	0.50	○			
F07.14	Timelag without Fault	0.01~30.00	S	10.00	○			
F07.15	Fault Retry Options	OL	ILP	SLU	SOU	SOC	11111	○
		1	1	1	1	1		
		0: Fault retry permitted 1: Fault retry prohibited SOC is LSB, arrange in logical order, the 6 th ~the 8 th bits are not used						
F07.16	Not Used							
F07.17	Disabled Trips	5~8 Bits				0000 0000	○	
		*	EEd	Eht	OL			
		0	0	0	0			
		1~4 Bits						
		tbr	OLP	ILP	SLU			
		0	0	0	0			
		0: Enabled, 1: Disabled SLU is LSB, arrange in logical order, the 8 th bit is not used						

F08 Group: Preset Speed and PLC Parameters

F08.00	Preset Speed 1	0.00~Fmax	Hz	0.00	●
--------	----------------	-----------	----	------	---

User Manual
EM100 Mini Inverter

F08.01	Preset Speed 2	0.00~Fmax	Hz	5.00	●														
F08.02	Preset Speed 3	0.00~Fmax	Hz	10.00	●														
F08.03	Preset Speed 4	0.00~Fmax	Hz	15.00	●														
F08.04	Preset Speed 5	0.00~Fmax	Hz	20.00	●														
F08.05	Preset Speed 6	0.00~Fmax	Hz	25.00	●														
F08.06	Preset Speed 7	0.00~Fmax	Hz	30.00	●														
F08.07	Program Operation Mode	<p>Ones place: Options of program operation mode 0: Monocycle 1: Operate as per Preset Speed 7 after monocycle 2: Limited times of continuous cycle 3: Continuous cycle</p> <p>Tens place: Options of stop and restart 0: Operate from the period when it stops 1: Operate from Preset Speed 1</p>		00	○														
F08.08	Program Operation Direction Setting	<table border="1" style="display: inline-table; border-collapse: collapse;"> <tr> <td>T 7</td> <td>T 6</td> <td>T 5</td> <td>T 4</td> <td>T 3</td> <td>T 2</td> <td>T 1</td> </tr> <tr> <td>0</td> <td>0</td> <td>0</td> <td>0</td> <td>0</td> <td>0</td> <td>0</td> </tr> </table> <p>0: Forward 1: Reverse T1 is LSB, arrange in order, the 8th bit is not used.</p>	T 7	T 6	T 5	T 4	T 3	T 2	T 1	0	0	0	0	0	0	0		0000000	○
T 7	T 6	T 5	T 4	T 3	T 2	T 1													
0	0	0	0	0	0	0													
F08.09	Program Operation Time T1	0~60000	S	30	●														
F08.10	Program Operation Time T2	0~60000	S	30	●														
F08.11	Program Operation Section T3	0~60000	S	30	●														
F08.12	Program Operation Time T4	0~60000	S	30	●														
F08.13	Program Operation Time T5	0~60000	S	30	●														

User Manual
EM100 Mini Inverter

F08.14	Program Operation Time T6	0~60000	S	30	●
F08.15	Program Operation Time T7	0~60000	S	30	●
F08.16	Speed Cycling Times	1~60000		1	●

F09 Group: PID Parameters					
F09.00	PID Reference Setting Mode	0: Numeric PID setting 1: Terminal VS 2: Terminal IS 3: Terminal VP		0	○
F09.01	PID Numeric Setting	0.0~100.0	%	50.0	●
F09.02	PID Feedback Options	0: Terminal VS 1: Terminal IS		0	○
F09.03	PID Setting/Feedback Scale	0~60000		1000	●
F09.04	PID Regulator Positive/ Negative Setting	0: Positive setting 1: Negative setting		0	○
F09.05	PID Output Gain	0.00~100.00	%	100.00	●
F09.06	Proportion Gain GP	0.00~100.00		0.40	●
F09.07	Integral Time GTi	0.00~300.00 0.00: No integration	S	10.00	●
F09.08	Differential Time GTd	0.00~300.00 0.00:No differentiation	mS	0.00	●
F09.09	Integration Function Scale	0.00~100.00	%	100.00	●
F09.10	PID Positive Output Limit	0.00~100.00	%	100.00	●
F09.11	PID Negative Output Limit	0.00~100.00	%	100.00	●
F09.12	PID Feedback Loss Detection Value	0.0~100.0	%	0.0	●
F09.13	PID Feedback Loss Detection Time	0.0~3000.0	S	1.0	●

F10 Group: Communication Parameters					
F10.00	Inverter Address	1~247, 0:Broadcasting address		1	○

User Manual
EM100 Mini Inverter

F10.01	Communication Bit Rate	0:4800 1:9600 2:19200 3:38400	bps	1	○
F10.02	Communication Format	0:No parity 1+8+1 1:Even parity 1+8+1+1 2:Odd parity 1+8+1+1		0	○
F10.03	Communication Overtime	0.0~60.0 0.0: Communication overtime disabled	S	0.0	○
F10.04	Master-slave Communication Mode	0:The inverter is the slave 1:The inverter is the master		0	○
F10.05	Master Writes the Address of Slave Inverter	0:Primary numeric frequency 1:Auxiliary numeric frequency		0	○
F10.06	Inverter Receiving Proportion Coefficient	0.00~600.00	%	100.00	●
F10.07	The Master Communication Sending Data	0: Input frequency 1: Output frequency 2: Primary numeric frequency 3: VP 4: VS 5: IS		0	○

F11 Group: User Parameters					
F11.00	Parameter Setting Control	0:Parameter setting permitted 1: Parameter lock 0 (Except F00.07 and F11.00, rest of the parameters cannot be edited.) 2: Parameter lock 1(Except F11.00, rest of the parameters cannot be edited.)		0	○
F11.01	User Password	0~65535		XXXXXX	○
F11.02	Parameter Editing Mode	0:Editable via keypad and RS485 1:Editable via keypad 2:Editable via RS485		0	○
F11.03	Inverter Rated Power	0.40~22	kW	XXXX	×

User Manual
EM100 Mini Inverter

F11.04	Inverter Rated Voltage	60~480	V	XXX	×
F11.05	Inverter Rated Current	0.1~100.0	A	XXXXXX	×
F11.06	Inverter Running Time	0~65535 User Monitoring	HOUR	XXXXXX	×
F11.07	Inverter Running Time	0~60 User Monitoring	min	XXXXXX	×
F11.08	Running Time Control	0: Disabled 1: Enabled		0	○
F11.09	Setting Running Time	0~65535	HOUR	XXXXXX	○
F11.10	Distributor Password	0~65535		XXXXXX	○
F11.11	Factory Password	0~65535		XXXXXX	○
F11.12	Software Version	0.00~600.00		XXXXXX	×

C00 Group: Monitoring Parameters					
C00.00	Output Frequency	0.00~Fup	Hz		×
C00.01	Actual Output Voltage	0~660	V		×
C00.02	Actual Output Current	0.0~300.0	A		×
C00.03	Output Power	0.0~50.0	kW		×
C00.04	Estimated Motor Speed	0~20000	rpm		×
C00.05	DC Bus Voltage	0~1200	V		×
C00.06	Input Frequency	0.00~Fmax	Hz		×
C00.07	Synchronous Frequency	0.00~Fup	Hz		×
C00.08	Program Operation Section	1~7			×
C00.09	Program Operation Time	0~60000	S		×
C00.10	PID Setting	0~60000			×
C00.11	PID Feedback	0~60000			×
C00.12	Input Terminal Status	** X6 X5 X4 X3 X2 X1 (Monitoring external input terminal logic status)			×

User Manual
EM100 Mini Inverter

C00.13	Output Terminal Status	***** R1 Y1(Monitoring output terminal logic status)			×
C00.14	VS Input Monitoring	0.00~10.00	V		×
C00.15	IS Input Monitoring	0.00~20.00	mA		×
C00.16	Inverter Heatsink Temperature	0~200	°C		×
C00.17	VP Input Monitoring	0~5.00	V		×

E00 Group: Fault Monitoring Parameters					
E00.00/ E00.01 /E00.02	The 1 st /2 nd /3 rd Most Recent Fault Records	00: No fault SC: Short circuit SOC: Stable overcurrent SOU: Stable overvoltage SLU: Stable undervoltage ILP: Input phase loss OL: Inverter overload OL1: Motor overload OH: Overheating OLP: Output Phase Loss EHt: External Fault EEd: Inverter EEPROM failure StP: Autotuning cancelled SrE: Stator resistance error SIE: Idling current error InP: Internal failure PIE: PID feedback loss COE: Communication overtime error SOFT: Inverter soft-start relay is off. tbr: Temperature sensor break		00	×
E00.03	Output Frequency at Last Fault	0.00~320.00	Hz	0.00	×
E00.04	Output Current at Last Fault	0.0~300.0	A	0.0	×
E00.05	DC Bus Voltage at Last Fault	0~1200	V	0	×

6. Parameter Description

F00 Group: General Parameters

No.	Function	Range	Unit	Default	Type
F00.00	Speed Reference Input Monitoring	Frequency 0.00~ Fmax	Hz	XXXXXX	X

F00.00 is only for reference. Its parameters are present frequency setting values. Symbol “-” will not be displayed if the value is negative, but user can check it via keypad indicator. See Chapter 4 for detail of keypad indicator description.

No.	Function	Range	Unit	Default	Type
F00.01	Drive Control Mode	0: V/F(Open loop control) 1: SVC		1	○





F00.01=0 V/F (Open loop control): Applicable to single-inverter driving multi-motor, and speed governing with low requirements on speed, low frequency torque, and speed accuracy.

F00.01=1 SVC: In this control mode, output current process is under real-time closed-loop control. Based on current feedback, inverter will conduct open-loop slip compensation and stator resistance voltage drop compensation on output variables. These 2 compensations are up to F05.10 and F05.11, or adjust F05.12 (Excitation boost gain) to adjust output frequency and torque slightly.

No.	Function	Range	Unit	Default	Type
F00.02	Start/Stop Control Options	Ones place: Start/Stop control mode options 0: Inverter keypad 1: Terminal 2: Communication Tens place: Terminal control mode options 0: RUN-Run, F/R-Forward/Reverse 1: RUN-Forward, F/R- Reverse 2: RUN-NO forward, Xi-NC stop, F/R-NO reverse 3: RUN-NO run, Xi-NC stop, F/R- Forward/Reverse		00	○

5 control commands of inverter: start, stop, forward, reverse and jog are under control of F00.02.

F00.02 Ones Place=0 Inverter keypad control

,
  and
  keys control the start/stop of inverter. If there is no fault, press
  to enter jog running status. Press
  to enter operation status. Green LED

indicator on  is on which refers to that inverter is in operation status, flashing refers to that inverter is in ramp-to-stop status.

F00.02 Ones Place=1 Terminal control

Control command given by multi-function input terminals RUN, F/R, FJOG, and RJOG. See the description of F00.02 tens place for detailed control logic.

F00.02 Ones Place=2 Communication control

Running command given by PC/PLC via Communication modes. See F10 Group for the communication parameters, and Appendix A: EM100 Modbus Communication Protocol.

F00.02 Tens place=0 Terminal RUN-run, F/R-forward/reverse (2-wire sequence control mode 1)

Terminal Xm is the running enabling terminal in this mode, and terminal Xn defines the running direction. See Table 6-1 for terminal function setting.

Table 6-1 Setting of 2-Wire Sequence Terminal Control Mode 1

Terminal	Setting Value	Description
Xm	1	RUN-run
Xn	2	F/R- forward/reverse

Xm and Xn are the multi-function terminals of X1~X6(F02.00~F02.05), and are on at PWL.(ON: the terminal is on. OFF: the terminal is off.)

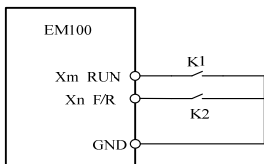

K1	K2	Run Command
OFF	OFF	Stop
OFF	ON	Stop
ON	OFF	Forward
ON	ON	Reverse

Figure 6-1 2-wire Sequence Terminal Control Mode 1

F00.02 Tens place=1 Terminal RUN-forward, F/R-reverse (2-wire sequence control mode 2)

It is the most commonly used 2-wire sequence control mode. Terminal Xm and Xn define forward and reverse of motor. See Table 6-2 for terminal function setting.

Table 6-2 Setting of 2-wire Sequence Terminal Control Mode 2

Terminal	Setting Value	Description
Xm	1	RUN-forward
Xn	2	F/R-reverse

Xm and Xn are the multi-function terminals of X1~X6(F02.00~F02.05), and are on at PWL.(ON: the terminal is on. OFF: the terminal is off.)

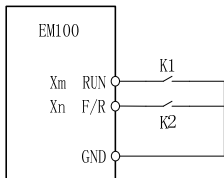

K1	K2	Run Command
OFF	OFF	Stop
OFF	ON	Reverse
ON	OFF	Forward
ON	ON	Maintain pervious running status

Figure 6-2 2-wire Sequence Terminal Control Mode 2



F00.02 start/stop selected as 2-wire sequence terminal control (F00.02=01 or F00.02=11), when terminal RUN or F/R is on, inverter stops with PLC section cycling stop command. Even control terminal RUN or F/R is on, the inverter will not run after stop command cancelled. If inverter needs to run, terminal RUN or F/R has to be triggered again.

F00.02 Tens place=2 Terminal RUN-NO forward, Xi-NC stop, and F/R-NO reverse (3-wire sequence control mode 1)

Xi is the enabling terminal in this mode. Xm and Xn define direction. See Table 6-3 for terminal function setting.

Table 6-3 Setting of 3-wire Sequence Terminal Control Mode 1

Terminal	Setting Value	Description
Xm	1	RUN-NO forward
Xn	2	F/R- Reverse
Xi	15	NC stop

Terminal Xi shall be on first if inverter has to run. Forward or reverse of motor is controlled by the pulse edge of Xm or Xn.

Terminal Xi shall be off if inverter has to stop.

Xm, Xn, and Xi are the multi-function terminals of X1~X6 (F02.00~F02.05).

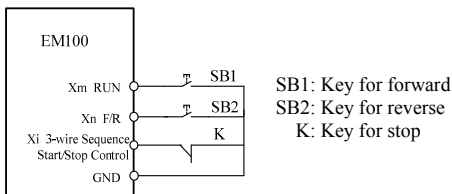

Figure 6-3 3-wire Terminal Control Mode 1

F00.02 Tens place=3 Terminal RUN-NO run, Xi-NC stop, F/R-Forward/ Reverse (3-wire control mode 2)

Xi is the enabling terminal in this mode. Xm gives run command, and Xn defines direction. See Table 6-4 for terminal function setting.

Table 6-4 Setting 3-wire Terminal Control Mode 2

Terminal	Setting Value	Description
Xm	1	RUN-NO run
Xn	2	F/R-Forward/reverse
Xi	15	NC stop

Terminal Xi shall be on first if inverter has to run. Pulse increasing edge of Xm generates motor running signal, and the status of Xn defines motor direction signal.

Terminal Xi shall be off if inverter has to stop.

Xm, Xn, and Xi are the multi-function terminals of X1~X6(F02.00~F02.05). Xm is on with pulse, and Xi and Xn are on at PWL.

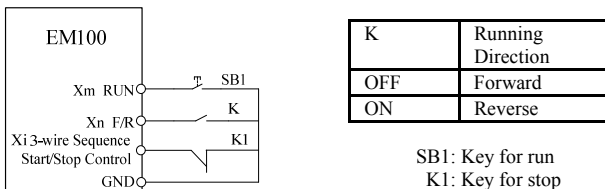

Figure 6-4 3-wire Terminal Control Mode 2

When inverter is in speed setting mode, it can be set by numeric setting, analog voltage, and analog current. Jog speed setting mode is prior to the other setting modes, i.e. press key or control terminal FJOG and RJOG are on, inverter will switch to jog speed setting mode automatically regardless of the present setting mode. See Figure 6-6 for detail of EM100 setting modes. See parameters description of F00.03, F00.04, and F00.05 for function codes of speed setting modes.

No.	Function	Range	Unit	Default	Type
F00.03	Primary Speed Setting Mode	0: Primary numeric frequency setting 1: VP keypad potentiometer 2: Terminal VS 3: Terminal IS		1	○

F00.03 For selecting the primary speed setting modes:

F00.03=0 Primary numeric frequency setting mode, defined by F00.07 parameters

F00.03=1 VP keypad potentiometer defines the setting frequency.

F00.03=2 Analog terminal VS voltage defines the setting frequency.

F00.03=3 Analog terminal IS current defines the setting frequency.



1. Default voltage of analog voltage input terminal VS: 0~10V.
2. Default current of analog current input terminal IS: 4~20mA.
3. Preset speed setting mode is prior to primary speed setting mode.

No.	Function	Range	Unit	Default	Type
F00.04	Auxiliary Speed Setting Mode	0: Auxiliary numeric frequency setting 1: VP keypad potentiometer 2: VS analog voltage input terminal 3: IS analog current input terminal 4~9: Not Used 10: Process PID 11: Program Operation 12: Wobulation Control		0	○

F00.04 For selecting auxiliary speed setting modes:

F00.04=0 Auxiliary numeric frequency setting mode, defined by F00.08 parameters.

F00.04=1 VP keypad potentiometer defines the setting frequency.

F00.04=2 Analog terminal VS voltage defines the setting frequency.

F00.04=3 Analog terminal IS current defines the setting frequency.

F00.04=4~9 Not used

F00.04=10 Process PID setting frequency defines the setting frequency.

See F09 Group for process PID setting parameters.

F00.04=11 Program operation setting frequency defines the setting frequency.

See F08 Group for program operation parameters.

F00.04=12 Wobulation operation setting frequency defines the setting frequency.

See F06 Group for wobulation operation parameters.

No.	Function	Range	Unit	Default	Type
F00.05	Integrated Speed Setting Mode	0: Primary speed setting 1: Auxiliary speed setting 2: Primary speed setting + Auxiliary speed setting 3: Primary speed setting - Auxiliary speed setting 4: MAX { Primary speed setting, Auxiliary speed setting } 5: MIN { Primary speed setting, Auxiliary speed setting }		0	○

F00.05 For selecting integrated frequency setting modes:

F00.05=0 Primary speed setting mode

F00.05=1 Auxiliary speed setting mode

F00.05=2 Primary speed setting + Auxiliary speed setting mode

F00.05=3 Primary speed setting - Auxiliary speed setting mode

F00.05=4 MAX {Primary speed setting, Auxiliary speed setting}

F00.05=5 MIN {Primary speed setting, Auxiliary speed setting}

No.	Function	Range	Unit	Default	Type
F00.06	Analog Integrated Speed Setting Mode	0: Integrated speed setting 1: VS* Integrated speed setting 2: IS* Integrated speed setting		0	○

F00.06 For selecting analog integrated speed setting modes.

F00.06=0 Integrated speed setting: The final significant speed value of F00.05 integrated speed.

F00.06=1 Defined by VS* Integrated speed setting

F00.06=2 Defined by IS* Integrated speed setting

No.	Function	Range	Unit	Default	Type
F00.07	Primary Numeric Frequency Setting	0.00~ Fmax	Hz	0.00	●
F00.08	Auxiliary Numeric Frequency Setting	0.00~ Fmax	Hz	0.00	●

F00.07 Operation frequency primary numeric setting value.

The parameter range: 0.00~Fmax upper limit frequency.

F00.08 Operation frequency auxiliary numeric setting value.

The parameter range: 0.00~Fmax upper limit frequency.



1. Press $\square \wedge / \square \nabla$ to edit F00.07 value directly. See Chapter 4 for the shortcut key description.
2. In primary numeric frequency setting mode, edit F00.07 value by terminal UP and DOWN directly.

No.	Function	Range	Unit	Default	Type
F00.09	Acceleration Time 1	0.01~600.00	S	15.00	●
F00.10	Deceleration Time1	0.01~600.00	S	15.00	●

Acceleration time is the time taken for the output frequency to rise from 0Hz up to maximum frequency Fmax (F00.11). Deceleration time is the time taken for the output frequency to drop from Fmax (F00.11) down to 0Hz. Both of them are not relevant to forward and reverse. As shown in Figure 6-5.

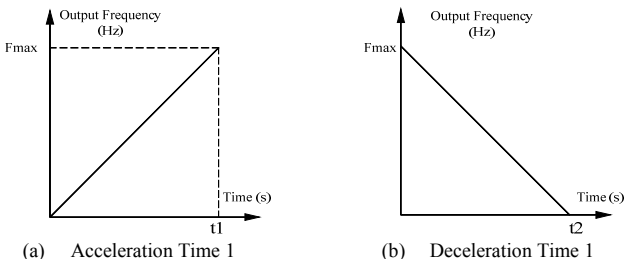

Figure 6-5 Acceleration/ Deceleration Time

2 groups of acceleration/ deceleration times of EM100 can be set as *Terminal for Switching Acceleration/ Deceleration Time 1/Time 2* by multi-function input terminal. Different terminal statuses are corresponding to relevant acceleration/ deceleration time. See the Table 6-5 for the correlation.

Table 6-5 Correlation between acceleration/ deceleration time and its switching terminal

Acceleration/ Deceleration Terminal Status	Acceleration/ Deceleration Time Option
OFF	Acceleration/ deceleration time group 1(F00.09, F00.10)
ON	Acceleration/ deceleration time group 2(F06.03, F06.04)

EM100 Speed Setting Input Modes

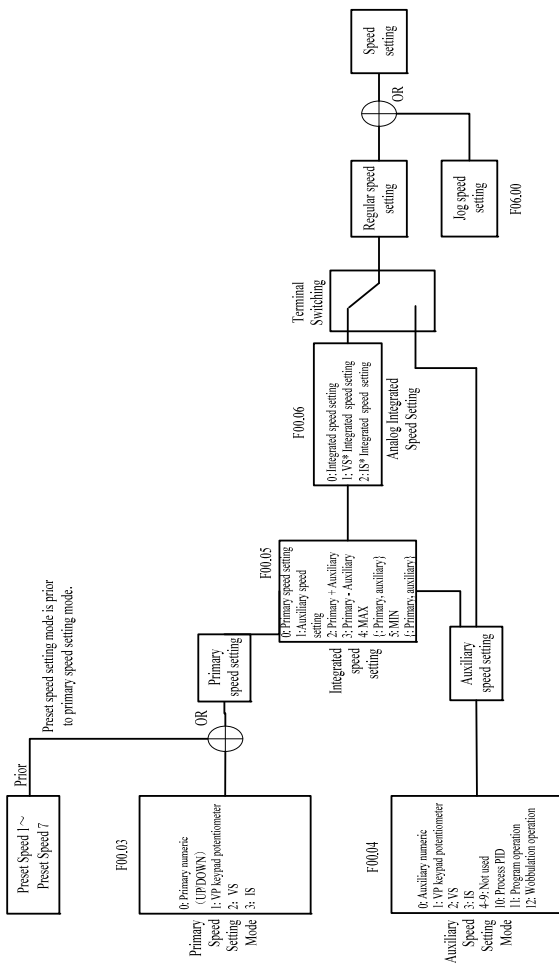

Figure 6-6 Speed Setting Input Mode

No.	Function	Range	Unit	Default	Type
F00.11	Maximum Frequency	Fmax:20.00~320.00	Hz	50.00	○
F00.12	Upper Limit Frequency	Fup:Fdown~Fmax	Hz	50.00	○
F00.13	Lower Limit Frequency	Fdown:0.00~Fup	Hz	0.00	○

F00.11 The maximum frequency (Fmax) can be set, and its range: 20.00~320.00Hz.

F00.12 The upper limit frequency (Fup) can be run after inverter starts, Fup range: Fdown~Fmax.

F00.13 The lower limit frequency (Fdown) can be run after inverter starts, Fdown range: 0.00~Fup.



1. Fup and Fdown shall be set as per motor nameplate parameters and working conditions. Motor shall not work in low frequency for a long time. Otherwise, motor service lifespan will be shortened due to overheating.

2. Correlation of Fmax, Fup and Fdown: $0.00\text{Hz} \leq \text{Fdown} \leq \text{Fup} \leq \text{Fmax} \leq 320.00\text{Hz}$

No.	Function	Range	Unit	Default	Type
F00.14	Motor Running Direction	0: Forward 1: Reverse		0	●

The rotating direction of motor can be changed by change of function code without changing the wiring of motor. It plays a role of changing motor rotating direction by switching any two wires of U, V, or W.

Remarks: After parameters are reset as defaults, motor running direction will return previous status. Do not edit F00.14 if the applications do not allow changing motor running direction after system adjusting finished.

No.	Function	Range	Unit	Default	Type
F00.15	Reverse Control	0: Reverse Permitted 1:Reverse Prohibited		0	○
F00.16	F/R Deadband	0.00~600.00	S	0.00	○

Motor reverse permission

F00.15=0 Reverse permitted: Motor running direction is set by F00.14, or controlled by terminal F/R.

F00.15=1 Reverse prohibited: Motor can only forward, F00.14 parameters are disabled, and terminal F/R is off.

Selecting motor status of switching forward/reverse

If setting F00.16=0, forward/reverse is in smooth transition.

If setting F00.16≠0, when switching forward/reverse and when motor speed drops to 0Hz, the inverter runs at 0Hz in F00.16 setting time, and then runs in opposite direction to setting frequency. As shown in Figure 6-7.

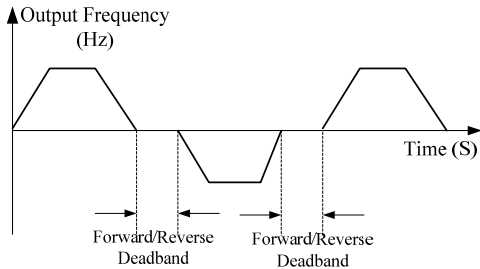

Figure 6-7 Forward/Reverse Deadband

No.	Function	Range	Unit	Default	Type
F00.17	Carrier Frequency	2.000~12.000	kHz	4.000	●
F00.18	Random Carrier Mode	0: Fixed carrier 1: Random carrier 2: Fixed carrier, which can be adjusted by carrier temperature and carrier current. 3: Random carrier, which can be adjusted by carrier temperature and carrier current.		2	●
F00.19	Upper Carrier Frequency	2.000~12.000	kHz	8.000	●
F00.20	Lower Carrier Frequency	2.000~12.000	kHz	2.000	●

F00.18=0 Fixed carrier

Carrier of inverter is a fixed value set by F00.17.

Increasing carrier frequency can reduce motor noise and heat, but it will increase temperature of inverter. When the carrier frequency is higher than the default, inverter rated power shall be decreased by 5% for every additional 1 kHz carrier frequency.

F00.18=1 Random carrier

Inverter carrier will vary with output frequency in linear variation. Upper/Lower carrier frequencies are under control of F00.19 and F00.20.

F00.18=2 Derating of fixed carrier

Inverter can adjust carrier value based on F00.17, carrier temperature and carrier current.

F00.18=3 Derating of random carrier

Inverter can adjust carrier value based on random carrier, carrier temperature and carrier current.

Carrier temperature adjustment refers to that inverter can adjust carrier frequency automatically based on its temperature. Carrier current adjustment refers to that inverter can adjust carrier frequency based on its current automatically.

No.	Function	Range	Unit	Default	Type
F00.21	Saving Setting Frequency Options	0: Do not save the frequency before power loss 1: Save the frequency before power loss		0	○
F00.22	Default Reset	0: Disabled 1: Reset default		0	○

Saving Setting Frequency Options

F00.21=0 Do not save the frequency before power loss

F00.21=1 Save the frequency before power loss

When power loss occurs, inverter will save primary numeric frequency, auxiliary numeric frequency, and program operation sections/time/cycling times.

Default Reset

F00.22=1 Reset default: Reset defaults of all parameters in F00, F02~F10 Group, and F00.22=0 automatically after resetting completed.

Remarks: Motor parameters (F01 Group) and user parameters(F11.03~F11.12 Group) will not be reset to defaults if conducting default reset.

F01 Group: Motor Parameters

No.	Function	Range	Unit	Default	Type
F01.00	Motor Rated Power	0.40~655.35	kW	XXXX	○
F01.01	Motor Rated Voltage	60~480	V	XXX	○
F01.02	Motor Rated Current	0.1~100.0	A	XXXXXX	○
F01.03	Motor Rated Frequency	20.00~320.00	Hz	XXXXXX	○
F01.04	Motor Rate Speed	1~20000	rpm	XXXXXX	○
F01.05	Motor Wiring Mode	0: Y Wiring 1: Δ Wiring		X	○
F01.06	Motor Rated Power Factor	0.70~0.95		XXX	○
F01.07	Motor Efficiency	70.00~97.00	%	XXXX	○

Remarks: When inverter connects to motor at the first time, set all parameters as per motor nameplate before operation starts.

No.	Function	Range	Unit	Default	Type
F01.08	Idling Excitation Current	0.1~100.0	A	XXXXXX	○
F01.09	Stator Resistance R1	0.01~300.00	Ω	XXXXXX	○
F01.10	Rotor Resistance R2	0.01~300.00	Ω	XXXXXX	○
F01.11	Stator& Rotor Mutual Inductance Lm	0.1~3000.0	mH	XXXX	○
F01.12	Leakage Inductance Coefficient	0.001~1.000		XXXX	○

User cannot know motor parameters F01.08~F01.12, please obtain these parameters by autotuning.

Before autotuning motor parameters, inverter will set motor nameplate parameters (Set by F01.00~F01.07) as the standard motor parameters automatically. See Figure 6-8 for the T equivalent model of the motor.

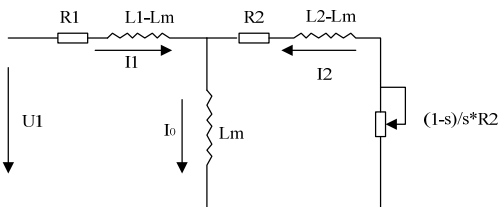

Figure 6-8 T Equivalent Model of 3-phase AC Induction Motor

R1, L1, R2, L2, Lm, and I_0 in Figure 6-8 refers to stator resistance, stator inductance, rotor resistance, rotor inductance, stator and rotor mutual inductance, and idling excitation current respectively.

Remarks: When changing motor rated power (F01.00) or motor rated voltage (F01.01), other corresponding motor parameters(F01.05~F01.12) will change automatically.

No.	Function	Range	Unit	Default	Type
F01.13	Autotuning Parameters	0:No autotuning 1:Stationary autotuning 2: Rotational autotuning (After setting mode 1 and 2, press RUN key.)		0	○

F01.13=0 No autotuning

F01.13=1 Motor remains motionless in the process of autotuning parameters (F01.10~F01.14).

F01.13=2 Motor is rotating in the process of autotuning parameters(F01.10~F01.14).

In stationary autotuning or rotational autotuning mode, set F01.13=1 or F01.13=2, and then press to start autotuning. After autotuning completed, F01.13=0 will be set automatically.

When autotuning is required, please set the Start/Stop control mode as the inverter keypad control mode, i.e. set ones place of F00.02=0. When slip compensation is active, autotune motor parameters first so that the motor will obtain the optimum performance.

F02 Group: Input Terminal Function Terminals

No.	Function	Range	Unit	Default	Type
F02.00	Multi-function Input X1-RUN	See Table 6-6		1	○
F02.01	Multi-function Input X2-F/R			2	○
F02.02	Multi-function Input X3-D1			3	○

F02.03	Multi-function Input X4-D2		4	○
F02.04	Multi-function Input X5-D3		5	○
F02.05	Multi-function Input X6-FRS		8	○

Table 6-6 Function of Multi-function Input Terminals

Setting Value	Function	Description
0	No function	To block terminal if terminal hardware failure occurs.
1	RUN -run	If start/stop control mode is in terminal control mode (F00.02=1~4), and if the terminal is on, the inverter will perform RUN functions as per setting value of terminal control mode.
2	F/R Forward/Reverse	If start/stop control mode is in terminal control mode (F00.02= 1~4), and if the terminal is on, the inverter will perform F/R functions as per setting value of terminal control mode.
3	Preset Speed Terminal 1	Define 3 function input terminals as preset speed terminals in preset speed control mode. Select a corresponding preset frequency in F08.00~F08.06 as present setting frequency via the integrated code of these 3 terminals.
4	Preset Speed Terminal 2	
5	Preset Speed Terminal 3	
6	Terminal for Switching Acceleration/Deceleration Time 1&2	Acceleration/deceleration time 1/2 set by F00.09/F00.10, F06.03/F06.04. Select corresponding acceleration/ deceleration time 1/2 via acceleration/ deceleration terminal status. Select acceleration/ deceleration time 1 if terminal is off, and acceleration/ deceleration time 2 if terminal is on.
7	Coast-to-stop	If the terminal is on when inverter is running, block PWM output, motor will coast to stop.
8	Inverter Fault Reset	After fault cleared, inverter can be reset through fault reset terminal.
9	FJOG Forward Jog	If terminal FJOG is on, motor forwards. If RJOG terminal is on, motor reverses. Motor will remain previous working status if two terminals are on simultaneously. ★ When reverse is prohibited, RJOG is off.
10	RJOG Reverse Jog	
11	Terminal UP	If input frequency is primary numeric frequency, its rate can be set by time integration of the key or stepping rate (F06.05).
12	Terminal DOWN	
13	UP/DOWN Clearing	Clear terminal UP/DOWN increasing or decreasing value.

14	Acceleration/ Deceleration Prohibition	If acceleration/deceleration prohibition terminal is on, it is prohibited performing acceleration/deceleration command. The inverter will keep output frequency unchanged, and will not be controlled by input frequency.
15	3-wire Sequence Run/Stop Control(Pulse Stop)	It is the NC stop key for 3-wire sequence terminal control.
16	DC Brake Input Command at Stop	When inverter is in the process of ramp-to-stop, and running frequency < DC brake frequency (Set by F04.06) at stop, if the terminal is on, DC brake starts, until the terminal is off, DC brake ends. If the terminal is on, and DC brake setting time is effective, take the bigger value between time when terminal is on and DC brake setting time at stop.
17	Switch Run Command to Terminal	If the terminal is on, no matter what running command mode F00.02 status is, it is in terminal control mode which has the highest priority. Terminal control mode is set by F00.02.
18	Program Running Reset	In program operation mode (PLC), if the input signal of the terminal is active, then program operation time will be cleared, cycling time cleared, and program operation starts from Preset Speed 1.
19	Switch to Auxiliary Speed Setting	In speed control mode, if the terminal is on, switch integrated speed setting mode to auxiliary speed setting mode, as set F00.05=1. After the terminal is off, it returns previous setting mode automatically.
20	External Fault Input	When inverter receives the external fault signals, it trips fault and coasts to stop.
21	Start Wobulation Operation	Wobulation running is under terminal control as selecting F06.18 ones place=1.

Table 6-7 Correlation between Preset Speed Terminal and Preset Speed Setting

Preset Speed	Terminal 3	Terminal 2	Terminal 1	Selected Frequency	Corresponding Setting Code
1	OFF	OFF	OFF	Keypad or Analog Setting	Defined by F00.03
2	OFF	OFF	ON	Preset Speed 1	F08.00
3	OFF	ON	OFF	Preset Speed 2	F08.01
4	OFF	ON	ON	Preset Speed 3	F08.02
5	ON	OFF	OFF	Preset Speed 4	F08.03
6	ON	OFF	ON	Preset Speed 5	F08.04
7	ON	ON	OFF	Preset Speed 6	F08.05
8	ON	ON	ON	Preset Speed 7	F08.06



1. Start/Stop of preset speed running is defined by F00.02.
2. When multi-function input terminal setting value is 6, acceleration/deceleration time of preset speed running is controlled and selected by the terminal.
3. Preset speed running will be affected by whether terminal F/R or RUN is ON (in terminal start/stop control mode). If terminal F/R is ON, the preset speed is reverse speed.
4. If reverse is required in the process of preset speed, please set inverter start/stop mode as terminal control mode, and set F00.15=0(Reverse permitted).

No.	Function	Range						Unit	Default	Type
		X6	X5	X4	X3	X2	X1			
F02.06	Multi-function Input Positive/Negative Logic	0	0	0	0	0	0	000000	○	
		0:Positive Logic Terminals are on at 0V/off at 24V 1:Negative Logic Terminals are off at 0V/ on at 24V X1 is LSB, arrange in logical order, the 7 th and the 8 th bits are not used.								
F02.07	Multi-function Input Filter Times	0~100							10	○
F02.08	X1 Input Delay Time	0.00~300.00						S	0.00	○
F02.09	X2 Input Delay Time	0.00~300.00						S	0.00	○

F02.06 Terminal Input Positive/Negative Logic

0: Positive logic—Terminals are on at 0V/off at 24V.

1: Negative Logic—Terminals are off at 0V/ on at 24V.

For codes displayed in binary system, if the 6th~8th bits require to be edited, press to shift to the 6th~8th bits. For codes (displayed in binary system) required to be edited in communication, see the following table for the value and corresponding decimal digit and hexadecimal digit.

Displayed Binary Value of F02.06	Corresponding Decimal Digit	Corresponding Hexadecimal Digit
00000000	0	0
00000001	1	1
00000010	2	2
.....
11111110	254	FE
11111111	255	FF

F02.07 Numeric Input Filter Times

Since multi-function input terminals take PWL trigger or pulse trigger mode, in order to avoid interference, numeric filter processing is required for reading terminal status. When filter times =1, the filter time is 0.50mS.

Generally, parameters of F02.07 rarely need adjustment. If adjustment is needed, note the correlation between the filter time and terminal active time to avoid interferences due to less filter times, or slow response and missing command due to more filter times.

F02.08 /F02.09 X1/X2 Input Delay Time

Refer to set the time how long the inverter delays to respond after the arrival of external signals.

No.	Function	Range	Unit	Default	Type
F02.10	VP Filter Time	0.00~10.00	S	0.10	●
F02.13	VS Filter Time	0.00~10.00	S	0.10	●
F02.14	IS Filter Time	0.00~10.00	S	0.10	●

Set filter time to filter process analog input signals for eliminating the effect of anti-interference signals. But excessively long filter time will reduce the response speed of analog signals. Generally, parameters of F02.08 /F02.09 rarely need adjustment.

No.	Function	Range	Unit	Default	Type
F02.11	VP Input Voltage Corresponding to 0.00Hz Frequency	0.0~100.0	%	1.0	●
F02.12	VP Input Voltage Corresponding to Maximum Frequency	0.0~100.0	%	98.0	●

Set values of F02.11 and F02.12 to achieve bias output of keypad potentiometer. See Figure 6-9 for principles of bias.

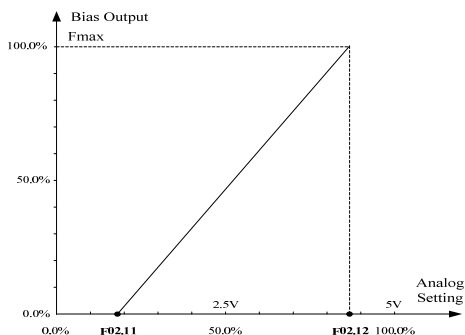

Figure 6-9 VP Input/Output Bias

No.	Function	Range	Unit	Default	Type
F02.15	VS Output Bias 0	-100.0~100.0	%	0.0	●
F02.16	VS Output Bias 1	-100.0~100.0	%	25.0	●
F02.17	VS Output Bias 2	-100.0~100.0	%	75.0	●

F02.18	VS Output Bias 3	-100.0~100.0	%	100.0	●
F02.19	VS Input Bias 0	0.0~VS Input Bias 1	%	0.0	●
F02.20	VS Input Bias 1	VS Input Bias 0~ VS Input Bias 2	%	25.0	●
F02.21	VS Input Bias 2	VS Input Bias 1~ VS Input Bias 3	%	75.0	●
F02.22	VS Input Bias 3	VS Input Bias 2~100.0	%	100.0	●

Output bias frequencies of 4 points in the middle of VS bias curve are defined by F02.15, F02.16, F02.17, and F02.18 respectively, range: -100.0%~100.0%.

100.0% is corresponding to Fmax.

Analog inputs of 4 points in the middle of VS bias curve are defined by F02.19, F02.20, F02.21, and F02.22 respectively, range: 0.0%~100.0%. They can be set in succession as $0 \leq F02.19 \leq F02.20 \leq F02.21 \leq F02.22$. Refer to the Figure 6-10 for the logic relations.

No.	Function	Range	Unit	Default	Type
F02.23	IS Output Bias 0	-100.0~100.0	%	0.0	●
F02.24	IS Output Bias 1	-100.0~100.0	%	25.0	●
F02.25	IS Output Bias 2	-100.0~100.0	%	75.0	●
F02.26	IS Output Bias 3	-100.0~100.0	%	100.0	●
F02.27	IS Input Bias 0	0.0~IS Input Bias 1	%	20.0	●
F02.28	IS Input Bias 1	IS Input Bias 0~ IS Input Bias 2	%	40.0	●
F02.29	IS Input Bias 2	IS Input Bias 1~ IS Input Bias 3	%	80.0	●
F02.30	IS Input Bias 3	IS Input Bias 2~100.0	%	100.0	●

Output bias frequencies of 4 points in the middle of IS bias curve are defined by F02.23, F02.24, F02.25, and F02.26 respectively, range: -100.0%~100.0%.

100.0% is corresponding to Fmax.

Analog inputs of 4 points in the middle of IS bias curve are defined by F02.27, F02.28, F02.29, and F02.30 respectively, range: 0.0%~100.0%. They can be set in succession as $0 \leq F02.27 \leq F02.28 \leq F02.29 \leq F02.30$.

For Instance:

Bias principles of VS and IS are identical. Following description is taken VS as the example.

1. Parameter setting

Table 6-8-1 Parameter setting 1

Code	Setting Value	Code	Setting Value
F02.15	-100%	F02.19	0.0%
F02.16	-50%	F02.20	25.0%
F02.17	70%	F02.21	75.0%
F02.18	100%	F02.22	100.0%

Table 6-8-2 Parameter setting 2

Code	Setting Value	Code	Setting Value
F02.15	100%	F02.19	0%
F02.16	70%	F02.20	40%
F02.17	-50%	F02.21	75%
F02.18	-100%	F02.22	100%

2. Diagram of output bias

See Figure 6-10-1 and Figure 6-10-2 for input/output bias of Table 6-8-1 and Table 6-8-2 respectively.

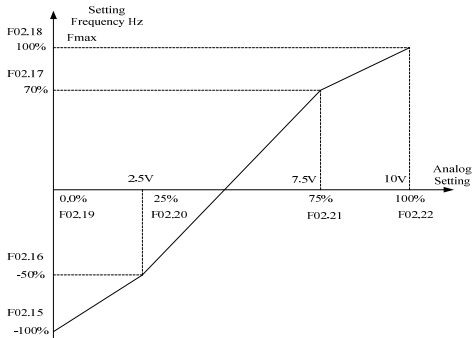

Figure 6-10-1 Input/Output Bias 1

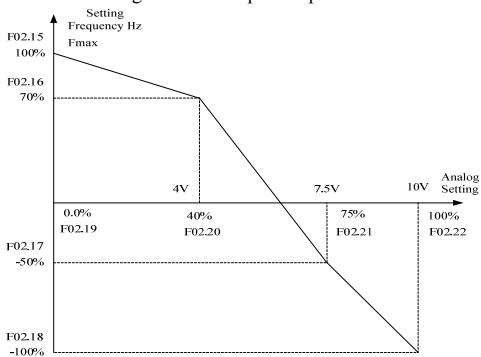

Figure 6-10-2 Input/Output Bias 2

F03 Group: Output Terminal Parameters

No.	Function	Range	Unit	Default	Type
F03.00	Multi-function Output Y1	0: Inverter is running 1: Frequency reach signal (FAR) 2: Output frequency range detection (FDT)		0	○
F03.01	Relay Output R1	3: Reverse running 4: Frequency reached upper limit 5: Frequency reached lower limit 6: Inverter fault 7: Inverter is ready to work 8: Overheating prealarm		6	○

EM100 provides 2 programmable numeric output terminals: 1 multi-function output terminal and 1 relay output terminal. 0~8 programming codes are available, user can define the output quantity of output terminals.

0: Inverter is running: When the inverter is running, Y1 or R1 is on.

1: Frequency reach signal (FAR): When the deviation between the output frequency and setting frequency of inverter in the frequency reaching detection range, Y1 or R1 is on. Refer to description of F06.06.

2: Frequency range detection (FDT): When output frequency of inverter > FDT increasing threshold, Y1 or R1 is on. When output frequency of inverter returns the FDT decreasing threshold, Y1 or R1 is off. Refer to description of F06.07/F06.08.

3: Reverse running: When output frequency of inverter is reversing, Y1 or R1 is on. When it is forwarding, Y1 or R1 is off.

4: Frequency reached upper limit: When the output frequency reached the upper limit (F00.12), Y1 or R1 is on.

5: Frequency reached lower limit: When the output frequency reached the lower limit (F00.13), Y1 or R1 is on.

6: Frequency fault: When inverter is in fault status, Y1 or R1 is on.

7: Inverter is ready to work: When power is on, inverter has no fault, soft-starter runs normally, Y1 or R1 is on.

8: When the temperature of fan \geq the setting of F07.09, Y1 or R1 is on.

No.	Function	Range	Unit	Default	Type
F03.02	Analog Output M0	See the Table 6-9 for M0 Programmable Code		0	○
F03.03	M0 Output Lower Limit	0.00~100.00	%	0.00	●
F03.04	M0 Output Upper Limit	0.00~100.00	%	100.00	●
F03.05	M0 Output Gain	0.00~300.00	%	100.00	●

EM100 provides 1 programmable analog output terminal M0. Analog output terminal outputs voltage signals (0~10V). See Table 6-9 for the signals and meanings of full scale corresponding to parameters.

Table 6-9 Programmable M0 Output

Setting Value	Function	Description
0	Output Frequency	0~Fmax corresponding to 0~10V
1	Input Command Frequency	0~Fmax corresponding to 0~10V
2	Output Current	0~2.0 times of inverter rated current corresponding to 0~10V
3	Output Voltage	0~1.5 times of inverter rated voltage corresponding to 0~10V
4	VS	0~10V
5	IS	0~10V corresponding to 0~20mA
6	+10V	10V (2mA MAX.)
7	DC Bus	0~1.5 times of inverter rated DC bus voltage corresponding to 0~10V

Analog output sets upper limit and lower limit to meet various needs.

$M0 \text{ Output Percentage} = M0 \text{ Lower Limit} + M0 \text{ Input Percentage} * M0 \text{ Output Gain} * (M0 \text{ Upper Limit} - M0 \text{ Lower Limit})$.

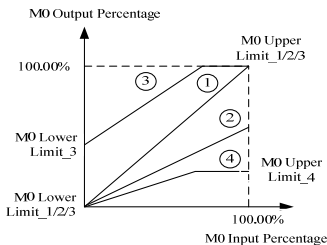

Figure 6-11 M0 Output Percentage Curves

4 curves obtained by set relevant M0 output parameters as shown in Figure 6-11:

Curve 1: Set as per the default.

Curve 2: Take curve 1 as the base to adjust M0 output gain.

Curve 3: Take curve 1 as the base to adjust M0 output gain and output lower limit.

Curve 4: Take curve 1 as the base to adjust M0 output gain and output upper limit.

F04 Group: Start/Stop Control Parameters

No.	Function	Range	Unit	Default	Type
F04.00	DC Brake Current at Start	0.00~150.00	%	0.00	○
F04.01	DC Brake Time at Start	0.00~30.00	S	0.00	○

F04.00 sets different values to achieve various DC brake torques at start.

F04.01 sets DC brake active time at start, inverter starts to run immediately when the time is up. If F04.01=0.00, DC brake is disabled at start. See Figure 6-12 for DC brake at start.

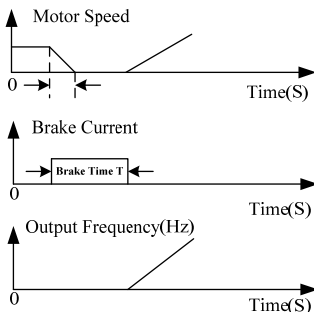

Figure 6-12 DC Brake Process at Start

No.	Function	Range	Unit	Default	Type
F04.02	Acceleration/ Deceleration Mode	0:Linear mode 1:S curve mode		0	○
F04.03	S Curve Time	0.00~600.00	S	0.00	○
F04.04	Not Used			-	-

Linear Acceleration/Deceleration

F04.02=0 Acceleration/Deceleration is in linear mode.

S Curve Acceleration/Deceleration

F04.02=1 Acceleration/Deceleration is in S curve mode. The 1st section and the last section in accelerating or decelerating are in smooth transition. The acceleration/deceleration curve is similar to S curve. When it is in S curve, the final acceleration/deceleration time= S curve time+ Linear acceleration/deceleration time. See Figure 6-13 for 2 acceleration/deceleration modes.

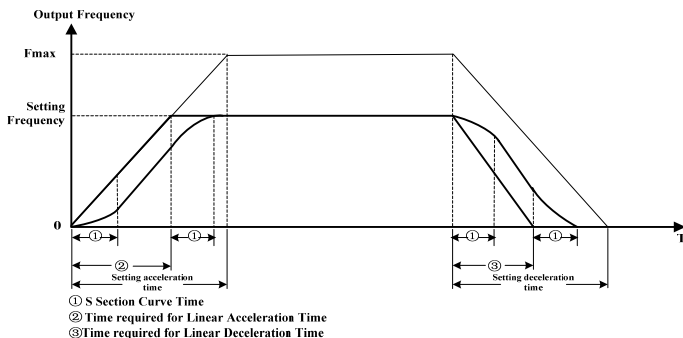

Figure6-13 Linear and S Curve Acceleration/Deceleration

No.	Function	Range	Unit	Default	Type
F04.05	Stop Mode Options	0: Ramp-to-stop 1: Coast-to-stop		0	○

Ramp-to-stop

Set F04.05=0, motor ramps to stop as per setting deceleration time 【(Default is as per F00.10 deceleration 1)】

Coast-to-stop

Set F04.05=1, inverter will block PWM output while inputting stop command, motor will coast to stop. Stop time is up to the motor and the load inertia. If a coast-to-stop terminal is set and when it is on, the inverter will enter coast-to-stop status immediately, and it will not run again if the terminal is off. It is required to input the run command again to restart inverter.

No.	Function	Range	Unit	Default	Type
F04.06	DC Brake Start Frequency at Stop	0.10~60.00	Hz	2.00	○
F04.07	DC Brake Current at Stop	0.00~150.00	%	2.00	○
F04.08	DC Brake Waiting Time	0.00~30.00	S	0.00	○
F04.09	DC Brake Time at Stop	0.00~30.00	S	0.00	○

F04.06 Set the frequency for DC brake to start in the process of ramp-to-stop. Once the output frequency is lower than this frequency in the process of ramp-to-stop, if DC brake time≠0 at stop, then DC brake enabled.

F04.07 Different setting values can define different DC brake torques at stop.

F04.08 When DC brake command given by the terminal is active at stop or the output frequency reaches the setting value of F04.06 in the process of ramp-to-stop. DC brake enabled after the time set by F04.06 is up.

F04.09 Set DC brake time at stop. If F04.09=0.00, the DC brake is disabled at stop. If there is a DC brake signal of external terminal at stop, then the DC brake time takes the bigger value between the active time of the terminal and the setting time of F04.09. See Figure 6-14 for DC brake process at stop.

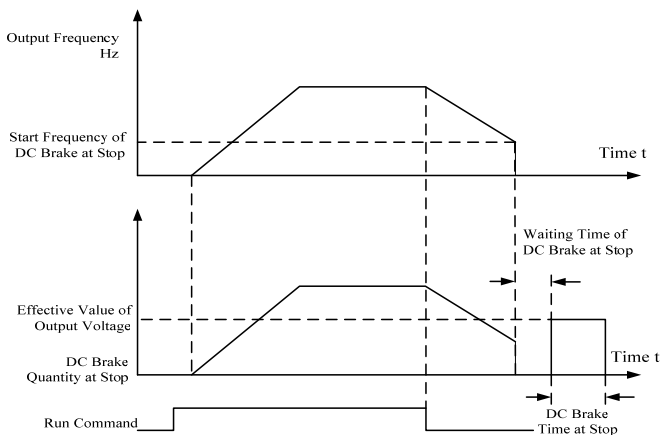

Figure 6-14 DC Brake Process at Stop

F05 Group: V/F Control Parameters

No.	Function	Range	Unit	Default	Type
F05.00	V/F Curve Scaling	See Table 6-15		35	●
F05.01	Frequency Base	Fbase:20.00~320.00	Hz	50.00	○

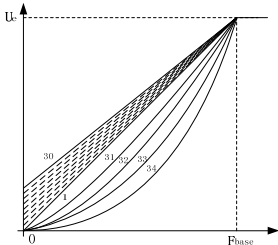

Figure 6-15 V/F Curves

Description:

- F05.00=0 Automatic torque boost
- F05.00=1~10 Fixed torque boost curve
- F05.00=11~20 Oil pump motor boost curve
- F05.00=21~30 Synchronous motor boost curve
- F05.00=31~34 Blower/water pump boost curve
- F05.00=35 Customer defined V/F curve scaling

F05.00#35 Select a fixed V/F boost curve, the output of Ue is corresponding to the setting value of F05.01.

No.	Function	Range	Unit	Default	Type
F05.02	Voltage 1	0.00~100.00	%	1.00	●
F05.03	Voltage 2	0.00~100.00	%	4.00	●
F05.04	Voltage 3	0.00~100.00	%	10.00	●
F05.05	Voltage 4	0.00~100.00	%	16.00	●
F05.06	Frequency 1	0.00~Frequency 2	%	1.00	●
F05.07	Frequency 2	Frequency 1~ Frequency 3	%	4.00	●
F05.08	Frequency 3	Frequency 2~ Frequency 4	%	10.00	●
F05.09	Frequency 4	Frequency 3~100.00	%	16.00	●

F05.00=35 Customer defined V/F curve scaling, user can set frequency and voltage points from F05.02~F05.09.

No.	Function	Range	Unit	Default	Type
F05.10	Open Loop Slip Compensation	0.00~200.00	%	150.00	●

Motor rotor speed will reduce as load increases. Start slip compensation to ensure motor rotor speed close to synchronous speed with the rated load, and increase setting value of F05.10 appropriately when motor speed is lower than the target value. F05.10=0, slip compensation is disabled.

No.	Function	Range	Unit	Default	Type
F05.11	Stator Voltagedrop Compensation Gain	0.00~100.00	%	80.00	●
F05.12	Excitation Boost Gain	0.00~300.00	%	180.00	●

Stator voltagedrop compensation is to compensate voltagedrop produced by stator resistance and connecting cable.

No.	Function	Range	Unit	Default	Type
F05.13	Oscillation Suppression	0.00~100.00	%	0.00	●

If output current is not stable, oscillation suppression is applied to limit current oscillation and to avoid overcurrent triggered by current oscillation when motor starts. It is also used to reduce vibration of motor and mechanical devices.

No.	Function	Range	Unit	Default	Type
F05.14	Overmodulation Level	1.00~1.10		1.00	●

Overmodulation level: If grid voltage is too low, in order to help the output voltage reach the rated voltage, the output voltage could be 1.1 times of present grid voltage after modulation.

No.	Function	Range	Unit	Default	Type
F05.15	AVR	0: Disabled 1: Enabled 2: AVR is disabled if the DC bus voltage > the rated voltage of DC bus, and it will be enabled if the DC bus voltage ≤ the rated voltage of DC bus.		0	○

Automatic voltage regulation is applied to the occasions when input voltage varies, output voltage remains unchanged basically, and V/F value keeps constant.

F06 Group: Auxiliary Function Parameters

No.	Function	Range	Unit	Default	Type
F06.00	Jog Numeric Frequency	0.00~ Fmax	Hz	5.00	●
F06.01	Jog Acceleration Time	0.01~600.00	S	15.00	●
F06.02	Jog Deceleration Time	0.01~600.00	S	15.00	●

In jog running mode, inverter runs as per the setting frequency of F06.00, and runs to the acceleration/deceleration time of Fmax set by F06.01/F06.02.

Jog acceleration time (F06.01) is the time taken for the output frequency to rise from 0Hz up to Fmax. Jog deceleration time (F06.02) is the time taken for the output frequency to drop from Fmax down to 0Hz.

 key should be active and terminal JOG should be on in jog running mode. Otherwise, jog command will be considered as cancelled.

No.	Function	Range	Unit	Default	Type
F06.03	Acceleration 2	0.01~600.00	S	15.00	●
F06.04	Deceleration 2	0.01~600.00	S	15.00	●

Details refer to the description of F00.09 and F00.10.

No.	Function	Range	Unit	Default	Type
F06.05	UP/DOWN Frequency Rate	0.00~100.00 Unit: Hz/ 200mS 0.00(Autorate integration)		1.00	●

In primary speed setting mode, edit primary speed setting (F00.07) via multi-function terminal UP/DOWN. Unit: Hz/200mS

F06.05=0.00: In autorate integration mode, edit F00.07 value slowly at beginning and then faster later based on the lasting time when terminal UP/DOWN is on.

F06.05≠0.00: Edit numeric setting value as per UP/DOWN rate set by F06.05 based on the lasting time when terminal UP/DOWN is on, calculate by Hz/200mS, only round-up, no round-off.

No.	Function	Range	Unit	Default	Type
F06.06	Frequency Reach Signal FAR	0.00~20.00	Hz	5.00	●

If multi-function output or relay output is set as 1(FAR), if absolute value of the difference between output frequency and input frequency of inverter is less than the setting value of F06.06, the corresponding output terminal is on. See Figure 6-16.

No.	Function	Range	Unit	Default	Type
F06.07	FDT Increasing Threshold	0.00~Fmax	Hz	30.00	○
F06.08	FDT Decreasing Threshold	0.00~Fmax	Hz	30.00	○

If multi-function output or relay output is set as 2(FDT), when the output frequency of inverter rises to the FDT increasing threshold (F06.07), the corresponding output terminal is on, and it will be off when the output frequency drops to the FDT decreasing threshold (F06.08). See Figure 6-17.

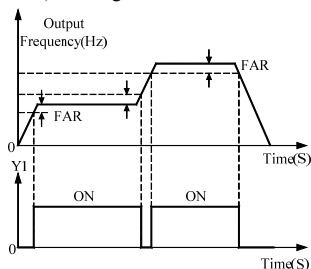

Figure 6-16 FAR

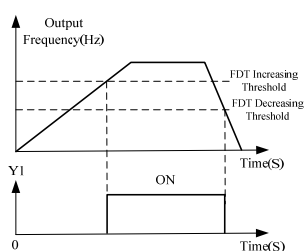

Figure 6-17 FDT

No.	Function	Range	Unit	Default	Type
F06.09	Output Voltage	5.00~100.00	%	100.00	●

Output voltage: If the inverter is not required to output the present voltage value, adjust the percentage of output voltage to input voltage.

No.	Function	Range	Unit	Default	Type
F06.10	Dynamic Brake Control	0: Disabled 1: Enabled 2: Enabled at running 3: Enabled at deceleration		1	○
F06.11	Dynamic Brake Voltage	380V:510~800 220V:300~400	V	700 380	○
F06.12	Brake Duty Ratio	5.0~100.00	%	100.00	○

F06.10 sets the enabling range of dynamic brake. When F06.10=0, dynamic brake is disabled. If F06.11≠0, dynamic brake enabled when meeting the setting value of F06.11.

F06.11 sets the voltage point of dynamic brake. If the present status meets the setting range of F06.10, DC bus voltage > setting voltage of F06.11, then dynamic brake is enabled.
380V: Inverter rated voltage is 380V. 220V: Inverter rated voltage is 220V.

F06.12 sets the duty ratio of voltage brake when dynamic brake is enabled.

No.	Function	Range	Unit	Default	Type
F06.13	Fan Control	0: Run at power-on 1: Smart mode		1	○

After power is on, the fan runs per the control mode after running for 2 minutes regardless of the working status of inverter.

F06.13=0 The fan runs directly after inverter is power-on.

F06.13=1 Smart mode: Fan runs if the temperature of heatsink >45℃. If the temperature of heatsink <35℃, fan stops. When the temperature of heatsink is between 35℃~45℃, fan remains its previous status.

No.	Function	Range	Unit	Default	Type
F06.15	JOG Key Function Setting	0: Disabled 1: Jog running function 2: F/R switching function		1	○

F06.15=0  key is disabled.

F06.15=1  key is for jog running.

F06.15=2  key is for switching forward and reverse.

No.	Function	Range	Unit	Default	Type
F06.16	Function of STOP Key	0: Enabled in keypad start/stop mode 1: Enabled in all start/stop modes 2: Enabled in keypad start/stop mode, external fault trips in other start/stop modes		0	○

F06.16=0 Enabled in keypad start/stop mode1, and disabled in other start/stop modes.

F06.16=1 Enabled in all start/stop modes.

F06.16=2 Enabled in keypad start/stop mode, external fault trips in other modes.

No.	Function	Range	Unit	Default	Type
F06.17	Customer Defined Scaling	0.01~200.00		30.00	●

F06.17 Customer Defined Scaling: Mechanical speed= Customer defined scaling (Mechanical speed coefficient) *Output frequency. Adjust the scaling to match the display speed value with the actual speed.

No.	Function	Range	Unit	Default	Type
F06.18	Wobulation Operation Mode	Ones place: Wobulation operation control 0: Auto-operation 1: Terminal Control Tens place: Wobulation input mode 0: Wobulation operation started after reaching mid-point 1: Wobulation operation starts when its preset time is up		00	○
F06.19	Preset Wobulation Frequency	0.00~Fmax	Hz	0.00	●
F06.20	Preset Wobulation Time	0.00~600.00	S	15.00	●
F06.21	Upper Limit Frequency of Wobulation	0.00~Fmax	Hz	40.00	●
F06.22	Lower Limit Frequency of Wobulation	0.00~Fmax	Hz	20.00	●
F06.23	Jump Frequency of Wobulation	0.00~Fmax	Hz	5.00	●
F06.24	Rising Time of Wobulation	0.00~600.00	S	15.00	●
F06.25	Dropping Time of Wobulation	0.00~600.00	S	5.00	●

Wobulation operation is a special program operation mode for the devices as textile machines which need to reciprocate.

Wobulation Operation Control Mode

F06.18 Ones place=0 Auto-operation

Wobulation operation starts when the preset wobulation time is up.

F06.18 Ones place=1 Terminal control

Wobulation operation is started by function input terminal when the preset wobulation time is up. If selecting terminal control mode, set any terminal among X1~X6=21.

Wobulation Input Mode

F06.18 Tens place=0 Wobulation operation starts after reaching middle frequency. Middle frequency = (Wobulation upper limit frequency+ Wobulation lower limit frequency) /2.

F06.18 Tens place=1 Wobulation operation starts when the preset wobulation time is up.

See Figure 6-18 for wobulation operation logic diagram.

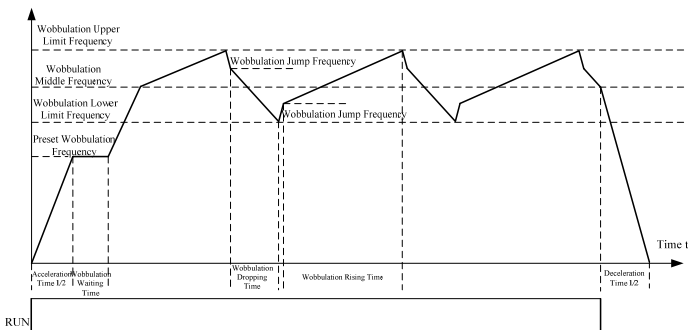

Figure 6-18 Wobulation Operation Logic Diagram

Remarks:

Wobulation operation start/stop acceleration/deceleration time can be selected by terminal as acceleration/deceleration time 1 or 2.

Set upper limit frequency of wobulation \geq Lower limit frequency of wobulation.

(Wobulation upper limit frequency-Jump frequency) and (lower limit frequency of wobulation+ Jump frequency) are set in the range of 0.00~Fmax.

Acceleration/deceleration time of wobulation jump frequency is wobulation acceleration/ deceleration time/ 2.

Starting process of wobulation operation: Select F00.04 auxiliary speed setting mode as wobulation operation, and integrated frequency setting mode is selected as auxiliary speed setting mode or other options including auxiliary speed setting mode.

No.	Function	Range	Unit	Default	Type
F06.26	Lower Limit Frequency Control	0: Run as per lower limit frequency 1: Run at zero speed when lower limit frequency running time is up.		0	○
F06.27	Lower Limit Frequency Running Time	0.00~600.00	S	60.00	○

F06.26=0 If output frequency of inverter < Lower limit frequency, inverter will always run as per lower limit frequency. F00.13 defines the lower limit frequency.

F06.26=1 If output frequency of inverter < Lower limit frequency, inverter runs as per lower limit frequency first, and runs in zero speed after lower limit frequency running time reached setting value of F06.27. This function is for process PID control as constant pressure water supply and air compressor.

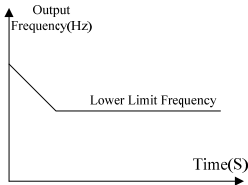

Figure 6-19-a F06.26=0

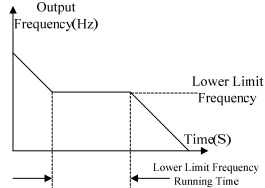

Figure 6-19-b F06.26=1

Figure 6-19 Lower Limit Frequency Control

No.	Function	Range	Unit	Default	Type
F06.28	Monitoring Code Options of Run/Stop Status	0: C00.00 1: C00.01 16: C00.16 17~99: Not Used 100: No change in keypad operation		0	○

In operation, jog running, stop, jog stop, and autotuning status, if F06.28=0~99, parameter setting status will change as the above mentioned statuses, inverter will display corresponding monitoring code value. If the status is changed from the above mentioned statuses to parameter setting status, keypad will display F00.00 code value. (Fault status will jump to E00.00 directly)

If F06.28=100, present keypad display will remain unchanged regardless of status change (Except the change is fault status.)

F07 Group: Fault and Protection Parameters

No.	Function	Range	Unit	Default	Type
F07.00	Current Limit Control	0: Current limit disabled 1: Current limit mode 1 2: Current limit mode 2		1	○
F07.01	Current Limit	50.00~180.00	%	150.00	○
F07.02	Frequency Decreasing Time (Limit Current in Constant Speed Operation)	0.00~600.00 Mode 1&2	S	5.00	●
F07.03	Current Limit Mode 2 Proportion Gain	0.01~10.00		0.30	●

F07.04	Current Limit Mode 2 Integral Time	0.00~300.00 0.00 Integration Disabled	S	10.00	●
---------------	---------------------------------------	---	---	-------	---

F07.00=0 Current Limit Control Disabled

F07.00=1 Current Limit Mode 1

During acceleration and deceleration, if output current exceeds current limit (F07.01), inverter stops acceleration/deceleration and remains at present running frequency, and will accelerate/decelerate as per previous acceleration/deceleration time after output current decreased.

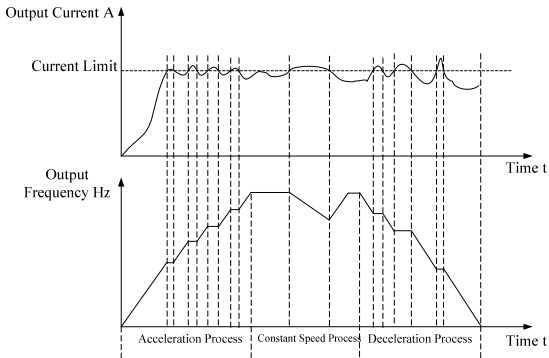

Figure 6-20 Current Limit Mode 1

During steady state, after output current exceeds the current limit (F07.01), inverter decelerates as per the decreasing time (F07.02) of constant speed current frequency, and the minimum deceleration could reach lower limit frequency (F00.13). After output current decreases, inverter will accelerate to setting frequency as per setting acceleration time, see Figure 6-20.

F07.00=2 Current Limit Mode 2

Current limit mode 2 is applied to the applications which are sensitive to acceleration/ deceleration time.

In this mode, the motor current is automatically adjusted by regulating the output frequency as per the PI parameter set in F07.03 and F07.04.

For load with larger inertia if overcurrent occurs during acceleration, the proportional gain may be increased. For overcurrent during deceleration, the proportional gain may be decreased.

For load with smaller inertia, the proportional gain may be kept smaller.

Integral time can be adjusted for fine tuning in both cases.

No.	Function	Range	Unit	Default	Type
F07.05	Overvoltage Stall Control	0: Overvoltage stall disabled 1: Overvoltage stall mode 1		1	○

		2: Overvoltage stall mode 2			
F07.06	Overvoltage Stall Voltage	380V: 640~800	V	750	○
		220V: 370~400		390	
F07.07	Overvoltage Stall Mode 2 Proportion Gain	0.01~10.00		0.30	●
F07.08	Overvoltage Stall Mode 2 Integral Time	0.00~300.00 0.00: Integration Disabled	S	10.00	●

F07.05=0 Overvoltage Stall Disabled.

F07.05=1 Overvoltage Stall Mode 1

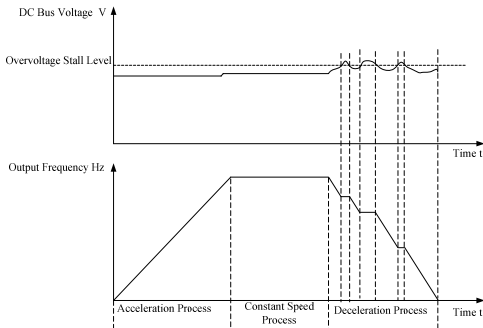

Figure 6-21 Overvoltage Stall Mode 1

In deceleration process, after DC bus voltage exceeds overvoltage stall voltage (F07.06), inverter stops deceleration process, and remains at present running frequency. After DC bus voltage decreases, inverter will decelerate as per previous deceleration time, see Figure 6-21.

F07.05=2 Overvoltage Stall Mode 2

Overvoltage stall mode 2 is applied to the applications which are sensitive to acceleration/ deceleration time.

In this mode, the motor frequency is automatically adjusted by DC bus voltage as per the PI parameters set in F07.07 and F07.08.

For load with larger inertia if overvoltage stall occurs during deceleration, the proportional gain may be increased.

For load with smaller inertia, the proportional gain may be kept smaller.

Integral time can be adjusted for fine tuning in both cases.

No.	Function	Range	Unit	Default	Type
F07.10	Motor Overload Protection Options	0: Prohibited 1: Permitted		1	○
F07.11	Motor Overload Protection Time	30~300	S	60	○

F07.10=0 No overload protection for motor, motor is in danger of overheating damage. A relay for overheating protection is suggested to be installed between motor and inverter.

F07.10=1 Inverter will judge whether motor is overloaded or not based on the inverse curve of motor overload protection.

F07.11 Motor overload protection time

The default is that inverter trips OL1 fault if 150% overload lasts for 1 minute at hot start, see Figure 6-22 for motor overload protection time. During normal operation, motor overload protection operates in the area between a cold start and a hot start.

Cold start: Motor protection operation time in response to an overload situation that was suddenly reached when starting a stationary motor.

Hot start: Motor protection operation time in response to an overload situation that occurred during sustained operation at rated current.

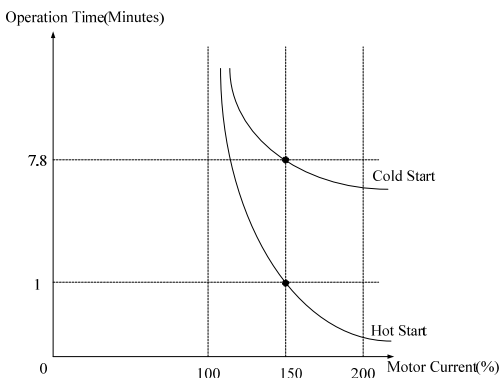

Figure 6-22 Motor Overload Protection Operation Time

No.	Function	Range	Unit	Default	Type
F07.12	Fault Retry Control	Ones place: Fault retry times 0: Fault retry prohibited 1~3: Fault retry for 1, 2, and 3 times 4: Unlimited fault retry Tens place: In the process of fault retry, fault output terminals: 0: Off 1: On		00	○
F07.13	Fault Retry Timelag	0.01~30.00	S	0.50	○
F07.14	Timelag without Fault	0.01~30.00	S	10.00	○

Fault Retry Times

F07.12 Ones Place=0

Fault occurs in the process of operation, inverter will not reset automatically, and it requires manual reset.

F07.12 Ones Place=1/2/3

Fault occurs in the process of operation, inverter stops output. After fault cleared, inverter resets fault automatically and restarts operation 1/2/3 times. The time that inverter takes to run without fault is over (F07.14), and the fault retry times resets to the setting value of F07.12 ones place. If fault retry is over 1/2/3 times, fault still occurs, and then there is no automatic fault reset.

F07.12 Ones Place=4

Fault occurs in the process of operation, inverter stops output. After fault cleared, inverter resets fault automatically and restarts operation until operating normally.

External Output at Fault Retry

F07.12 Tens place=0

During the period of fault retry, fault output terminal and fault relay are disabled.

F07.12 Tens place=1

During the period of fault retry, fault output terminal and fault relay are enabled.

Fault Retry Timelag

F07.13 controls the timelag of fault retry. Fault retry timelag refers to the period from no fault output to resetting fault automatically.

Parameter value is in the range of 0.01~30.00S and can be set in succession.

Timelag without Fault

F07.14 controls the time for inverter resetting fault retry times. Fault occurs in operation process, after reset and restarted, inverter will record the fault reset times. If no fault occurs in the setting time of this code, the inverter will clear the fault reset times automatically.

Timelag without fault: 0.01~30.00 seconds and can be set in succession.

	<p>1. In the process of operation, start features of mechanic devices should be taken into consideration. Fault reset cannot be conducted if the applications which cannot start with load or the applications require alarming immediately after inverter does not output.</p> <p>2. In auto-reset timelag, inverter blocks PWM output, and motor is in coast-to-stop status.</p>
---	--

No.	Function	Range					Unit	Default	Type
		OL	ILP	SLU	SOU	SOC			
F07.15	Fault Retry Options	1	1	1	1	1		11111	○
		0: Fault retry permitted 1: Fault retry prohibited SOC is LSB, arrange in logical order, the 6 th ~the 8 th bits are not used							

Fault retry is bit operation. Set the corresponding bit of fault as 0 or 1.

For instance: SOU and OL fault retry are permitted, other fault retries are prohibited. Set the first corresponding bit of SOU=0 and the 4th corresponding bit of OL=0, other bits=1, i.e. F07.15=11101101

No.	Function	Range	Unit	Default	Type
F07.17	Disabled Trips	5~8 Bits		0000 0000	○
		* EED Eht OL			
		0 0 0 0			
		1~4 Bits			
		tbr OLP ILP SLU			
		0 0 0 0			
		0: Enabled 1: Disabled SLU is LSB, arrange in logical order, the 8 th bit is not used			

Bit setting value=0

After detecting the fault corresponding to the bit, inverter stops output and then enters fault status.

Bit setting value=1

After detecting the fault corresponding to the bit, inverter remains previous status without protection.

F07.17 is bit operation, only set corresponding bit to protection=0/1. As shown in the following table, for instance: Only set the 2nd bit corresponding to ILP=1 to disable ILP protection, i.e. F07.17=00000010. Set the 3rd bit corresponding to OLP=1 and the 7th bit corresponding to EHT=1 to disable OLP and EHT, i.e. F07.17=01000100.



1. Never disable any trip protection function unless special requirement, in case of inverter damage if there is no protection trip after fault occurs.
2. Refer to binary system parameter setting description of F02.06.
3. OLP detection is enabled when the absolute value of output frequency > 5.00Hz.

F08 Group: Preset Speed and PLC Parameters

No.	Function	Range	Unit	Default	Type
F08.00	Preset Speed 1	0.00~ Fmax	Hz	0.00	●
F08.01	Preset Speed 2	0.00~ Fmax	Hz	5.00	●
F08.02	Preset Speed 3	0.00~ Fmax	Hz	10.00	●
F08.03	Preset Speed 4	0.00~ Fmax	Hz	15.00	●
F08.04	Preset Speed 5	0.00~ Fmax	Hz	20.00	●
F08.05	Preset Speed 6	0.00~ Fmax	Hz	25.00	●
F08.06	Preset Speed 7	0.00~ Fmax	Hz	30.00	●
F08.07	Program Operation	Ones place: Options of program		00	○

	Mode	operation mode 0: Monocycle 1: Operate as per Preset Speed 7 after monocycle 2: Limited times of continuous cycle 3: Continuous cycle Tens place: Options of stop and restart 0: Operate from the period when it stops 1: Operate from Preset Speed 1			
F08.08	Program Operation Direction Setting	T7 T6 T5 T4 T3 T2 T1 0 0 0 0 0 0 0		0000000	○
		0: Forward 1: Reverse T1 is LSB, arrange in order, the 8 th bit is not used.			
F08.09	Program Operation Time T1	0~60000	S	30	●
F08.10	Program Operation Time T2	0~60000	S	30	●
F08.11	Program Operation Time T3	0~60000	S	30	●
F08.12	Program Operation Time T4	0~60000	S	30	●
F08.13	Program Operation Time T5	0~60000	S	30	●
F08.14	Program Operation Time T6	0~60000	S	30	●
F08.15	Program Operation Time T7	0~60000	S	30	●
F08.16	Speed Cycling Times	1~60000		1	●

Speed Program Operation Mode Options

F08.07 Ones place=0 Inverter stops after the operation of 7 program operation sections finished as per the time and direction.

F08.07 Ones place=1 Inverter runs as per Preset Speed 7 after the operation of 7 program operation sections finished as per the time and direction.

F08.07 Ones place=2 After the operation of 7 program operation sections finished as per the time and direction, inverter returns Preset Speed 1 in cycling operation. When the cycling operation times reach the setting value, inverter will stop. F08.16 defines the cycling times

F08.07 Ones place=3 After the operation of 7 program operation sections finished as per the time and direction, inverter returns Preset Speed 1 in cycling operation, and will cycle continuously unless giving a stop command.

Operation Stopped and Restart Options

F08.07 Hundreds place=0 If external fault terminal is on in the process of program operation, after power loss or fault occurred, inverter enters operation status to run as per the section at stop(including the section at stop, the remaining running time and setting operation frequency).

F08.07 Hundreds place=1 If external fault terminal is on in the process of program operation, after power loss or fault occurred, then enter operation status, program operation starts from Preset Speed 1.

Running Direction Options

F08.08 All Bits=0 Positive input, motor forwards, output is positive torque.

F08.08 All Bits=1 Negative input, motor reverses, output is negative torque.

If setting F00.15 as reverse permitted, reverse is disabled in program operation. If the 0th bit of F08.08 set as 1 or function terminal setting is reverse command. Inverter will run at 0Hz in Preset Speed 1. Operation of each section will follow the same pattern.

Operation Time

F08.09~F08.15 define the operation time of each section in program operation and can be set in succession, range: 0~60000 seconds.

If program operation section is 0 second, program operation will skip this section.

See Figure 6-23 for program operation diagram.

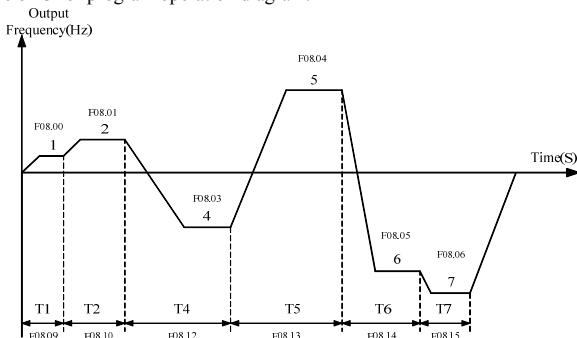

Figure 6-23 Program Operation Diagram

In Figure 6-23, the operation time of Preset Speed 3 is set as 0. Therefore, Preset Speed 3 does not operate.

In program operation, operation frequency, operation time, and positive/negative input can be set.

Inverter runs as per the operation frequency of preset speed 1-7 set by F08.00-F08.06.

Start process of EM100 program operation: Select F00.04 auxiliary speed setting mode as program operation, select integrated frequency setting mode as auxiliary speed setting mode or other options including auxiliary speed setting mode.

F09 Group: Process PID Parameters

PID control is a closed-loop control mode which feedbacks the output signal of control object in the system to PID controller, and then form closed-loop by adjusting the output of controller after PID calculation. PID control is to make the output value of control object in the system identical to the setting target value.

Based on the error between system setting target and feedback signal, PID controller computes the control variables with proportion, integration and differentiation. The characteristics of each computing factor are as follows:

Proportion (P):

Proportion control is a simplest control mode. The output and input error signal of its controller is in proportional relation. The stable errors of system output exist in proportional control mode only. The stable error refers to the difference between expected output of system and actual output after system response is stable.

Integration (I):

In integration control mode, the output and input error signal integration of controller is in direct ratio. It can eliminate stable error and keep the system away from stable errors after entering stable status, but sharp changes cannot be tracked.

Differentiation (D):

In differentiation control mode, the output and input error signal differentiation (i.e. the change ratio of error) of controller is in direct ratio. It can forecast the trend of error change with quick response, and improve the dynamic performance of system in the process of regulation.

See Figure 6-25 for control logic diagram of EM100 internal process PID. EM100 and its control object can form an inverse feedback control system via PID closed-loop control function.

Start process of EM100 process PID: Select F00.04 auxiliary speed setting mode as process PID, select integrated frequency setting mode as auxiliary speed setting mode or other options including auxiliary speed setting mode.

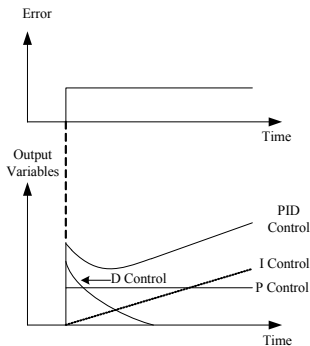

Figure 6-24 Function of PID Control

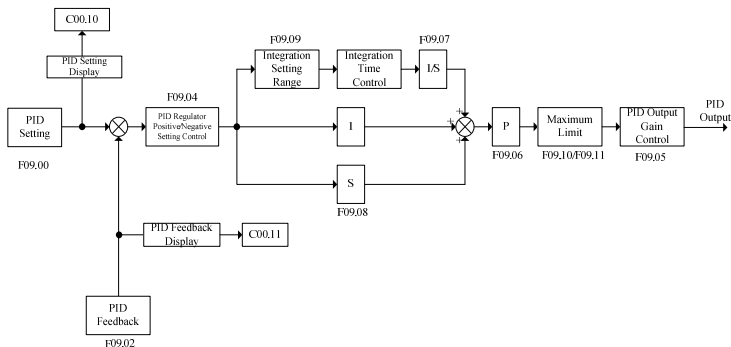

Figure 6-25 Control Logic Diagram of EM100 Internal Process PID

No.	Function	Range	Unit	Default	Type
F09.00	PID Reference Setting Mode	0: Numeric PID setting 1: Terminal VS 2: Terminal IS 3: Terminal VP		0	○
F09.01	PID Numeric Setting	0.0~100.0	%	50.0	●

F09.00=0 Numeric PID setting.

Input PID setting value by editing F09.01 parameters via keypad.

F09.00=1

Take the input voltage percentage of analog input terminal VS as PID setting value.

F09.00=2

Take the voltage percentage converted from input current of analog input terminal IS as PID setting value.

F09.00=3

Take the input voltage percentage of potentiometer VP as PID setting value.

No.	Function	Range	Unit	Default	Type
F09.02	PID Feedback Options	0: Terminal VS 1: Terminal IS		0	○

PID feedback signal is input by analog input terminal. The feedback value can be operated mathematically based on real needs.

F09.02=0 The input voltage percentage of analog input terminal VS is PID feedback value.

F09.02=1 The input current percentage of analog input terminal IS is PID feedback value.

No.	Function	Range	Unit	Default	Type
F09.03	PID Setting/Feedback Scale	0~60000		1000	●

The percentage of PID setting * F09.03 and percentage of PID feedback * F09.03 will obtain the unit value of corresponding physical quantity (Temperature, pressure, and flow rate) will be displayed in C00.10 (PID setting value) and C00.11 (PID feedback value).

No.	Function	Range	Unit	Default	Type
F09.04	PID Regulator Positive/ Negative Setting	0: Positive setting 1: Negative setting		0	○

F09.04=0 Positive setting: Error and output are positive.

F09.04=1 Negative setting: Error is positive, output is negative.

If PID setting signals increase, the output frequency of inverter is required to rise, for instance: if controlling flow rate or pressure, PID regulator should be under positive setting control.

If PID setting signals increase, the output frequency of inverter is required to drop, for instance: if controlling temperature, PID regulator should be under negative setting control.

No.	Function	Range	Unit	Default	Type
F09.05	PID Output Gain	0.00~100.00	%	100.00	●

F09.05 Output gain is for adjusting PID output. Unit: %

No.	Function	Range	Unit	Default	Type
F09.06	Proportion Gain GP	0.00~100.00		0.40	●
F09.07	Integral Time GTi	0.00~300.00, 0.00: No integration	S	10.00	●
F09.08	Differential Time GTd	0.00~300.00, 0.00: No differentiation	mS	0.00	●

F09.06 Proportion gain GP is the proportion gain of PID closed-loop control algorithm.

F09.07 Integration time GTi is the integral time constant of PID closed-loop control algorithm. When integral time is 0, integration function is disabled.

F09.08 Differentiation time GTd is the differentiation time of PID closed-loop control algorithm. When integral time is 0, differentiation function is disabled.

No.	Function	Range	Unit	Default	Type
F09.09	Integration Function Scale	0.00~100.00	%	100.00	●

F09.09 Integration function scale: When error between PID setting value and feedback is bigger than some setting value, then the integral operation will not go on. The setting value is the integration function scale.

Setting value of F09.09= |(Setting value - Feedback)/Setting value|

Set inverter in the process PID closed-loop control mode, and adjust the parameters of PID controller based on the output waveforms through the output of feedback signal monitoring system. Generally, adjusting by following the rules:

- Increase the proportion gain GP within the range of non-oscillation output.
- Reduce integration time GTi within the range of non-oscillation output.
- Increase differentiation time GTd within the range of non-oscillation output.

After all PID parameters set, all of them can be slightly adjusted by following steps:

Output overshoot suppression: Shorten the differentiation time GTd, and prolong the integral time GTi, as shown in Figure 6-26.

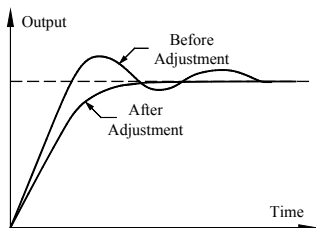

Figure 6-26
Output Overshoot Suppression

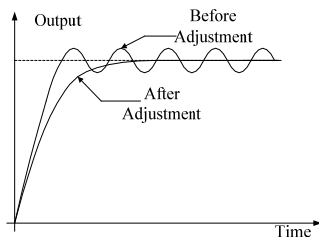

Figure 6-27
Output Periodic Oscillation Suppression

Output periodic oscillation suppression: Shorten the differentiation time GTd or set it as 0, and reduce proportion gain GP, as shown in Figure 6-27.

No.	Function	Range	Unit	Default	Type
F09.10	PID Positive Output Limit	0.00~100.00	%	100.00	●
F09.11	PID Negative Output Limit	0.00~100.00	%	100.00	●

Set PID output percentage within the range of [-F09.11, F09.10]

No.	Function	Range	Unit	Default	Type
F09.12	PID Feedback Loss Detection Value	0.0~100.0 0.0: No detection on feedback loss	%	0.0	●
F09.13	PID Feedback Loss Detection Time	0.0~3000.0	S	1.0	●

F09.12/F09.13 are for PID feedback loss detection.

If PID feedback < PID feedback loss detection value (F09.12), and lasting time > PID feedback loss detection time (F09.13), inverter trips PIDE (PID feedback loss) and will take the corrective action based on selected troubleshooting. In order to prevent false alarm of PIDE trip, please do not set F09.12=0.1 or 0.2.

F10 Group: Communication Parameters

EM100 supports Modbus protocol, RTU format, and processes single-master/ multi-slave communication network of RS485 bus.

No.	Function	Range	Unit	Default	Type
F10.00	Inverter Address	1~247 0: Broadcasting address		1	○

Inverter address code is the address code allocated to each inverter when the inverter is connected to the PC/PLC network. Each address code is unique in this network. The maximum number of inverter is 247 which are permitted to connect to the PC/PLC in one network.

F10.00=0 Address code is broadcasting address. When setting broadcasting address, inverter would not respond signals to PC/PLC.

No.	Function	Range	Unit	Default	Type
F10.01	Communication Bit Rate	0: 4800 1: 9600 2: 19200 3: 38400	bps	1	○

F10.01=0 Communication Bit Rate: 4800bps

F10.01=1 Communication Bit Rate: 9600bps

F10.01=2 Communication Bit Rate: 19200bps

F10.01=3 Communication Bit Rate: 38400bps

No.	Function	Range	Unit	Default	Type
F10.02	Communication Format	0:No parity 1+8+1 1:Even parity 1+8+1+1 2:Odd parity 1+8+1+1		0	○

F10.02=0 No parity

F10.02=1 Even parity

F10.02=2 Odd parity

No.	Function	Range	Unit	Default	Type
F10.03	Communication Overtime	0.0~60.0 0.0: Communication overtime disabled	S	0.0	○

If set F10.03=0.0, communication overtime disabled. If set F10.03≠0.0, and if the interval between giving order and communication response is over communication overtime, inverter will trips COE (RS485 Communication Overtime Error). Generally, it will be set as disabled, only set as enabled if F10.04=0(The inverter is the slave).

No.	Function	Range	Unit	Default	Type
F10.04	Master-slave Communication Mode	0:The inverter is the slave 1:The inverter is the master		0	○
F10.05	Master Writes the Address of Slave Inverter	0:Primary numeric frequency 1:Auxiliary numeric frequency		0	○
F10.06	Inverter Receiving Proportion Coefficient	0.00~600.00	%	100.00	●

F10.04 Master-slave communication mode

Select the present inverter as the master or the slave.

F10.05 Master writes the address of slave inverter

Select master inverter to send the frequency setting to the slave, and select to edit primary numeric frequency (F00.07) and auxiliary numeric frequency (F00.08) of the slave. F10.05 is only enabled if F10.04=1 (The inverter is the master).

F10.06 Inverter receiving proportion coefficient

This function defines the numeric frequency (received by the slave from the master)* the proportion coefficient of F10.06, which is the actual frequency setting received by the slave.

No.	Function	Range	Unit	Default	Type
F10.07	The Master Communication Sending Data	0:Input frequency 1:Output frequency 2:Primary numeric frequency 3:VP 4:VS 5:IS		0	○

If setting F10.04=1, the inverter is the master, select frequency source sending from the master to the slave via F10.07.

F10.07=0 The master sends input frequency.

F10.07=1 The master sends output frequency.

F10.07=2 The master sends primary numeric frequency.

F10.07=3 VP input voltage percentage sent by the master*Fmax

F10.07=4 VS input voltage percentage sent by the master*Fmax

F10.07=5 IS input current percentage sent by the master*Fmax

F11 Group: User Parameters

No.	Function	Range	Unit	Default	Type
F11.00	Parameter Setting Control	0:Parameter setting permitted 1: Parameter lock 0 2: Parameter lock 1		0	○
F11.01	User Password	0~65535		XXXXXX	○
F11.02	Parameter Editing Mode	0:Editable via keypad and RS485 1:Editable via keypad 2:Editable via RS485		0	○

Parameter Setting Control

F11.00=0 Parameter setting permitted

F11.00=1 Parameter lock 0(Except F00.07 and F11.00, rest of the parameters cannot be edited.)

Parameter lock 1(Except F11.00, rest of the parameters cannot be edited until the parameter is unlocked.)

User Password

F11.01 is for setting a password to start password protection function to prevent parameters from being edited by non-professionals. If the new password is 0, the password function is disabled.

Parameter Editing Mode

F11.02=0 Editable via keypad and RS485

F11.02=1 Editable via keypad

F11.02=2 Editable via RS485.

No.	Function	Range	Unit	Default	Type
F11.03	Inverter Rated Power	0.40~22.00	kW	XXXX	X
F11.04	Inverter Rated Voltage	60~480	V	XXX	X
F11.05	Inverter Rated Current	0.1~100.0	A	XXXXXX	X

The parameters are only for reference and cannot be edited. Please verify the parameters with the nameplate before operation.

No.	Function	Range	Unit	Default	Type
F11.06	Inverter Running Time	User Monitoring	HOUR	XXXXXX	X
F11.07	Inverter Running Time	User Monitoring	min	XXXXXX	X
F11.08	Running Time Control	0: Disabled 1: Enabled		0	○
F11.09	Setting Running Time	0~65535	HOUR	00000	○

F11.06 Hours that inverter has run. The parameters are only for reference and cannot be edited. Running time is the time accumulation of operation status.

F11.07 Minutes within 1 hour that inverter has run. The parameters are only for reference and cannot be edited.

F11.08=0 Running time control disabled.

F11.08=1 Running time control enabled, if the setting operation time is up, inverter trips InP (Internal fault), and cannot run.

F11.09 For controlling the operation time of inverter.
The permitted operation time = F11.09 -F11.06.

No.	Function	Range	Unit	Default	Type
F11.10	Distributor Password	0~65535		XXXXXX	○
F11.11	Factory Password	0~65535		XXXXXX	○

In order to prevent the key parameters from being edited and resulting in faults, the parameters are only for professionals.

No.	Function	Range	Unit	Default	Type
F11.12	Software Version	-		XXXXXX	X

The parameters are only for reference and cannot be edited.

C00 Group: Monitoring Parameters

When EM100 is running, operation parameters can be acquired by checking monitoring parameters in C00 Group. Details of all monitoring parameters are read only.

No.	Function	Range	Unit
C00.00	Output Frequency	Present output frequency of inverter	Hz
C00.01	Actual Output Voltage	Present actual output voltage of inverter	V
C00.02	Actual Output Current	Present actual output current of inverter	A
C00.03	Output Power	Inverter calculates present output power based on output voltage and output current	kW
C00.04	Motor Estimated Speed	Estimated motor speed	rpm
C00.05	DC Bus Voltage	Present DC bus voltage of inverter.	V
C00.06	Input Frequency	Present setting frequency value of inverter	Hz
C00.07	Synchronous Frequency	Synchronous frequency of motor estimated by inverter	Hz
C00.08	Program Operation Section	Section of monitoring inverter program operation	
C00.09	Program Operation Time	Operation time in present operation section when monitoring inverter in program operation	S
C00.10	PID Setting	Present PID setting value	
C00.11	PID Feedback	Present PID feedback value	
C00.12	Input Terminal Status	* X6 X5 X4 X3 X2 X1	
		0 0 0 0 0 0 0	
		(Monitoring external input terminal logic status)	
C00.13	Output Terminal Status	* * * * * * R1 Y1	
		0 0 0 0 0 0 0 0	
		(Monitoring output terminal logic status)	
C00.14	VS Input Monitoring	0.00~10.00	V
C00.15	IS Input Monitoring	0.00~20mA	mA
C00.16	Inverter Heatsink Temperature	Present detected temperature of inverter heatsink	℃
C00.17	VP Input Monitoring	0.00~5.00	V

7. Troubleshooting

7.1 Fault and Corrective Action

When anything unexpected happened, the corresponding trip code and parameters will be displayed on the keypad. Fault relay is enabled, and fault output terminal is on, and inverter output stops. When fault occurs, if the motor is running, and it will coast to stop until stopped. See Table 7-1 for EM100 fault trips and troubleshooting.

Table 7-1 EM100 Fault Trips and Corrective Action

Trip Code	Trip	Cause	Corrective Action
<i>SC</i>	Short Circuit	<ol style="list-style-type: none"> 1. Short circuit between inverter output phases, or between the output phases and ground. 2. IGBT is damaged. 	<ol style="list-style-type: none"> 1. Check, take corrective actions, and then reset. 2. Technical support required.
<i>SOC</i>	Stable Overcurrent	<ol style="list-style-type: none"> 1. Short circuit between inverter output phases or between the output phases and ground. 2. When load is too heavy, the acceleration/deceleration time is too short. 3. In V/F control mode, the setting value of torque boost is too big. 4. The motor is rotating when inverter starts. 5. The capacity of motor exceeds that of inverter. 	<ol style="list-style-type: none"> 1. Check, take corrective actions, and then reset. 2. Prolong acceleration/deceleration time 3. Reduce setting value of torque boost. 4. Set speed search enabled. 5. Replace with applicable motor or inverter.
<i>SOU</i>	Stable Overvoltage	<ol style="list-style-type: none"> 1. Voltage of power grid is too high. 2. Deceleration time is too short. 	<ol style="list-style-type: none"> 1. Lower voltage to the rated voltage. 2. Prolong the deceleration time.
<i>SLU</i>	Stable Undervoltage	<ol style="list-style-type: none"> 1. Input power phase loss. 2. Wiring terminal of input power is loose. 3. Voltage fluctuation of input power is too big. 4. Switch contact of input power is aging. 	<ol style="list-style-type: none"> 1. Check input power supply. 2. Tighten screws on input terminals. 3. Check air switch and contactor.
<i>ILP</i>	Input Phase Loss	Input power phase loss.	<ol style="list-style-type: none"> 1. Check input power supply. 2. Check wiring of input power supply. 3. Check if wiring terminal is loose.

<i>OL</i>	Inverter Overload	<ol style="list-style-type: none"> 1. Acceleration/ deceleration time is too short. 2. The setting value of torque boost is too big in V/F control mode. 3. Load is too heavy. 	<ol style="list-style-type: none"> 1. Prolong acceleration/ deceleration time. 2. Reduce setting value of torque boost. 3. Replace with the inverter which is applicable to the load.
<i>OLI</i>	Motor Overload	<ol style="list-style-type: none"> 1. If motor protection parameter(F07.11) setting is proper 2. If load is too heavy or motor rotor is blocked. 3. Inverter is not applicable. 	<ol style="list-style-type: none"> 1. Set the parameter correctly. 2. Reduce load and check mechanical conditions of motor. 3. Select inverter in high power rating.
<i>OH</i>	Heatsink Overheating	<ol style="list-style-type: none"> 1. Ambient temperature is too high. 2. Poor ventilation. 3. Cooling fan is broken down. 4. The temperature sensor on the heatsink is short-circuit. 	<ol style="list-style-type: none"> 1. The service environment of inverter should meet requirement. 2. Improve environmental ventilation, and check if the vent of inverter is blocked. 3. Replace air cooling fan.
<i>OLP</i>	Output Phase Loss	<ol style="list-style-type: none"> 1. Output phase U, V, or W loss 	<ol style="list-style-type: none"> 1. Check the connection between inverter and motor. 2. Check if motor wiring is broken. 3. Check if the output terminal is loose.
<i>EHt</i>	External Fault	<ol style="list-style-type: none"> 1. External device fault terminal acts. 	Check external devices.
<i>EEd</i>	Inverter EEPROM Failure	<ol style="list-style-type: none"> 1. Interference makes EEPROM read-write mistakes. 2. EEPROM is damaged. 	<ol style="list-style-type: none"> 1. Press STOP/RESET button to reset, and then retry. 2. Technical support required.
<i>StP</i>	Autotuning Cancelled	<ol style="list-style-type: none"> 1. During autotuning, press STOP/RESET key. 	Press STOP/RESET button to reset.
<i>StE</i>	Stator Resistance Error	<ol style="list-style-type: none"> 1. Motor is not connected to the output terminals of inverter. 	<ol style="list-style-type: none"> 1. Check connection between inverter and motor.
<i>SI E</i>	Idling Current Error	<ol style="list-style-type: none"> 2. Motor is on load. 3. Motor is broken down. 	<ol style="list-style-type: none"> 2. Motor is offloaded. 3. Check motor.
<i>PI dE</i>	PID Feedback Loss	<ol style="list-style-type: none"> 1. PID feedback < Setting value of F09.12 	<ol style="list-style-type: none"> 1. Check PID feedback signal or set a proper value for F09.12.

<i>COE</i>	Communication Overtime Fault	1. Improper bits rate setting. 2. Communication cable failure.	1. Check if the setting of Communication overtime is proper, and verify the applying program Communication setting.
<i>INP</i>	Internal Fault	1. Scheduled stop function enabled when the setting time is up.	1. Contact distributors or SINEE.
<i>SOFT</i>	Inverter Charge Relay Loss	1. Grid voltage is too low during running. 2. Rectifier of inverter is damaged.	1. Check grid voltage 2. Contact distributors or SINEE.
<i>tbr</i>	Temperature sensor break	1. Temperature sensor detecting wire failure.	1. Contact distributors or SINEE.

When inverter trips any above fault, and if it is required to exit from fault status, press STOP/RESET key to reset and clear the fault. If the fault is cleared, inverter will return function setting status. But if the fault is not cleared, LED keypad will display present fault information.

7.2 Common Fault and Troubleshooting

After power is on, due to improper function setting and incorrect wiring between inverter and external control terminals, motor cannot conduct the expected performance.

7.2.1 Parameter Setting Failures

- Press \triangle or ∇ , the displays of parameters remain unchanged.
Some parameters can only be edited when the inverter stopped.
- Press \triangle or ∇ , the displays of parameters change, but they cannot be saved.
Some parameters cannot be edited since they are locked.

7.2.2 Abnormal Motor Operation

- **Press RUN key, the motor does not run.**
 - Start/Stop is in terminal control mode: Check the setting of F00.02.
 - Coast-to-stop terminals FRS and GND are on: Disconnect FRS from GND.
 - When the terminal (Run Command Switched to Terminal) is on, the run command is only controlled by terminal at mean time: Switch the terminal off.
 - Status combination of run command inputs is in terminal control mode: Change it to keypad control mode.
 - Setting reference input frequency=0: Increase reference input frequency.
 - Abnormal power supply or control circuit problems.
- **Control terminals RUN, F/R=ON, the motor does not run.**
 - The external terminal start/stop setting is disabled: Check the setting of F00.02.
 - Coast-to-stop terminal FRS=ON: Switch FRS=OFF.
 - Control switch is disabled: Check control switch.
 - Setting reference input frequency=0: Increase reference input frequency.

➤ In 3-wire sequence control mode, 3-wire sequence run/stop control terminal is off, switch it on.

● **Motor can only run in one direction.**

Reverse prohibited: When F00.15=1, inverter is prohibited to reverse.

● **Motor reverses**

The output phase sequence of inverter is not identical to that of motor input: When power is off, the running direction of motor can be changed by switching any of the two connection wires, or editing F00.14 without turning the power off.

7.2.3 Excessively Long Acceleration Time

● **Excessively low setting of current limit**

When setting overcurrent limit is enabled, if the output current of inverter reaches the setting current limit (F07.01), then the output frequency will remain unchanged in the process of acceleration, and it will rise continuously only until it is lower than the setting of F07.01. Therefore, the acceleration time of motor is longer than the setting time. Check if the setting of F07.01 is excessively low.

● **If the setting acceleration time is too long, confirm its parameters.**

7.2.4 Excessively Long Deceleration Time

● **When dynamic brake enabled**

➤ The brake resistance is too big. The dynamic brake power is too small, so the deceleration time is prolonged.

➤ The setting value (F06.12) of brake duty ratio is too small, and the deceleration time is prolonged. Increase the setting value of brake duty ratio.

➤ The setting deceleration time is too long, confirm its parameters.

● **When overvoltage stall protection enabled**

➤ Overvoltage stall protection acts, when DC bus voltage exceeds overvoltage stall point (F07.06), the output frequency remains unchanged. When it is below overvoltage stall point (F07.06), the output frequency drops continuously. Therefore, the deceleration time is prolonged.

➤ The setting deceleration time is too long, check its parameters.

7.2.5 Inverter Overheating

● **Excessively heavy load**

➤ Heavy load makes inverter work beyond its rated current for a long time. The power of inverter shall be applicable to that of motor.

➤ The motor rotor is blocked due to the failure of motor or load.

● **Excessively high ambient temperature**

When the ambient temperature of inverter exceeds the permitted value, the temperature might exceed the permitted highest value of inverter when it works in the rated status.

7.2.6 EMI and RFI

● **When inverter runs in high frequency switch status, it will generate EMI and RFI to the control devices. Take following countermeasures:**

➤ Lower the carrier frequency (F00.17) of inverter.

- Install noise filter on input and output side of inverter.
- Shield cable with a metal tube, and place the inverter in a metal case.
- Inverter and motor shall be grounded reliably. The main circuit and the control circuit should be separated in terms of wiring. Control circuit should take shielded wire, and see Chapter 3 for wiring.

7.2.7 Leakage Circuit Breaker for Leakage Protection

● **When inverter runs, the leakage circuit breaker is triggered for leakage protection.**

Since inverter outputs high frequency PWM signal, it will generate high frequency leakage current. Select a special leakage circuit breaker with a trigger current $\geq 30\text{mA}$, or a regular leakage circuit breaker with a trigger current $\geq 200\text{mA}$ and the action time $\geq 0.1\text{S}$.

7.2.8 Mechanical Vibration

● **The fixed frequency of mechanical system resonates with the carrier frequency of inverter.**

The machine resonates sharp noise due to the resonance between the fixed frequency of mechanical system and the carrier frequency of inverter. Adjust the carrier frequency F00.17 to avoid resonant frequency.

● **The fixed frequency of mechanical system resonates with the output frequency of inverter.**

- The fixed frequency of mechanic system resonates with the output frequency of inverter which will generate mechanical noise.
- Adjust F05.13 oscillation suppression parameters to clear mechanical vibration.
- Install the anti-vibration rubber on the chassis of motor or take some other anti-vibration measures.

● **PID Control Oscillation**

Improper setting of adjusting parameters P, Ti and Td of PID controller, reset PID parameters.

7.2.9 Inverter Stops Output While Motor Runs

● **Insufficient DC brake at stop**

- DC brake torque at stop is too small, increase setting value of DC brake current at stop (F04.07).
- DC brake time is too short at stop, increase setting value of DC brake time (F04.09).

7.3.10 Output Frequency Does Not Output as per the Setting Frequency

● **The setting frequency exceeds the upper limit frequency**

When the setting frequency exceeds the setting value of upper limit frequency, output frequency outputs as per the upper limit frequency. Reset the setting frequency to make it within the range of upper limit frequency, or check whether F00.11 and F00.12 are proper.

8. EMC (Electromagnetic Compatibility)

8.1 Definition

Electromagnetic compatibility is the ability of the electric equipment to run in the electromagnetic interference environment and implement its function stably without interferences on the electromagnetic environment.

8.2 EMC Standard Description

In accordance with the requirements of the national standard GB/T12668.3, the inverter needs to comply with electromagnetic interference and anti-electromagnetic interference requirements. EM100 applies the latest international standard — IEC/EN61800-3: 2004 (Adjustable speed electrical power drive systems part 3: EMC requirements and specific test methods), which is equivalent to the national standard GB/T12668.3.

IEC/EN61800-3 assesses the inverter in terms of electromagnetic interference and anti-electromagnetic interference. Electromagnetic interference mainly tests the radiation interference, conduction interference and harmonics interference on the inverter (required for the inverter for civil use). Anti-electromagnetic interference mainly tests the conduction interference rejection, radiation interference rejection, surge interference rejection, fast and mutable pulse group interference rejection, ESD interference rejection and power low frequency end interference rejection.

The tests shall be conducted strictly in accordance with the above requirements of IEC/EN61800-3, and EM100 shall be installed and used in accordance with the instruction in 8.3 and has good electromagnetic compatibility in general industry environment.

8.3 EMC Guide

8.3.1 Harmonic Effect

Higher harmonics of power supply may damage the inverter. Thus, at some places where mains quality is rather poor, it is recommended to install AC input reactor or current harmonic filter.

Due to impact of harmonics, see 3.6 wiring of main circuit on input side for selecting input leakage breaker.

8.3.2 Electromagnetic Interference and Installation Precautions

1. The earth wires of the inverter and other electric products shall be well grounded.
2. The input and output power cables of the inverter and weak current signal cables (e.g. control signal cable) shall not be arranged in parallel and vertical arrangement is preferable.
3. The output power cables of the inverter are recommended to employ shield cables or steel pipe shielded cables and the shielding layer shall be grounded reliably. The signal cables are recommended to employ twisted-pair shielded control cables, and the shielding layer shall be grounded reliably.
4. When the length of motor cable is longer than 50 meters, the output filter or reactor is required.

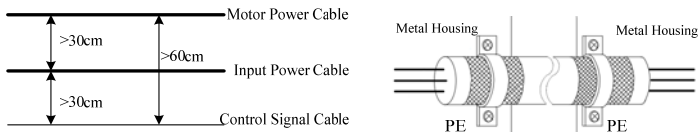

Figure 8-1 Wiring and Shielded Grounding

8.3.3 Grounding

1. Inverter and other devices shall be grounded. If a common grounding point is required, single point grounding is suggested, and common grounding cable is not recommended.
2. A grounding cable with large cross-section shall be taken for ensuring low grounding impedance. For the cables with the same cross-sectional area, high frequency impedance of flat conductor is smaller than that of a round conductor. Therefore it is better to take flat cable. The grounding cable should be as short as possible, and the distance should be as close as possible between the grounding point and the inverter.
3. If motor power cable is the quad cable, the grounding wire of quad cable must be grounded in the inverter side, and the other side is connected to the grounding terminal of the motor. The best grounding effect could be obtained if the motor and inverter have their separated grounding points.
4. If the grounding terminals of all parts are connected together in the control system, the noise source formed by the ground leakage current would affect the other peripherals in the control system except inverter. Therefore, in the same control system, the groundings shall be separated for the inverter and electrical devices such as computers, sensors or audio.
5. In order to obtain lower HF impedance, take the fixing bolts as the HF terminal connected to the cabinet back panel. Remove the insulating paint on the fixing point at installation.
6. Laying grounding cables should be kept away from the wiring of noise-sensitive device I/O part, while, the grounding cable should be as short as possible.

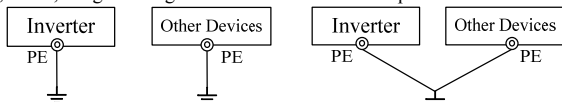

Figure 8-2 Correct Grounding Mode for Inverter and Other Devices

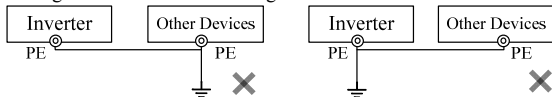

Figure 8-3 Incorrect Grounding Mode for Inverter and Other Devices

8.3.4 Handling the EMI of the peripherals on the inverter

The electromagnetic interference is generated because of relays, contactors and electromagnetic brakes installed nearby the inverter. When the inverter has malfunction due to EMI, following methods are recommended:

1. Install surge absorber on the devices generating interference.
2. Install EMC filter on the input power cable of inverter, refer to 8.3.7 for specific operations procedures.

3. The control signal cable and the detection line of the inverter employ shielded cable or twisted-pair cable, and the shielding layer shall be grounded reliably.

8.3.5 Handling the EMI of the Inverter on the Peripherals

These interferences include two types: one is radiation interference of the inverter, and the other is conduction interference of the inverter. Refer to the following methods for handling different interferences:

1. For the measuring meters, receivers and sensors, their signals are generally weak. If they are placed nearby the inverter or together with the inverter in the same control cabinet, they are easy to encounter interference and thus malfunctions are generate. The following methods are recommended
 - Put in places far away from the interference source
 - Do not arrange the signal cables with the power cables in parallel and never bind them together.
 - Both the signal cables and power cables employ shielded cables and are well earthed.
 - Install ferrite magnetic ring for the power cable (nickel-zinc ring with suppressing frequency > 30MHz) at the output side of the inverter and wind it 2 to 3 cycles.
 - Install EMC output filter in more severe conditions.
2. When the devices interfered and the inverter shall the same power supply, it may cause conduction interference. Install EMC input filter between the inverter and the power supply. Refer to 8.3.7 for specific operation procedures).
3. The peripherals are separately grounded which can lower common-mode interference caused by common-ground impedance.

8.3.6 Leakage Current and Handling

Distributed capacitance exists in power cable and the earth. The longer the power cable is and the bigger distributed capacitance to the earth is, and the bigger the leakage current is. The higher the carrier frequency is, and the bigger the leakage current is. Reduce leakage current by shortening power cable and lowering carrier frequency.

8.3.7 Precautions for Installing EMC Filter at the Input of Power Supply

1. Since the filter belongs to Classification I electric appliances, the metal housing of the filter shall be well connected to the metal ground of the installing cabinet. It is required to have good conduction continuity. Otherwise, there may be danger of electric shock and the EMC effect may be greatly affected.
2. Through the EMC test, it is found that the filter ground must be connected with the PE end of the inverter at the same common earth. Otherwise the EMC effect may be greatly affected.
3. The filter shall be installed at a place as close as possible to the input of the power supply, and the input cable of filter power supply shall be as short as possible in the control cabinet.
4. If the input and output lines of the filter is too close, the HF interference will by-pass the filter, and couple the input and output lines of the filter directly. The power supply filter will be functionless.
5. Typically there is a special grounding terminal on the filter housing. However, if the filter is connected to the control cabinet housing with a wire, it cannot prevent HF interference. It is because the long cable has big HF impedance, the filter would not play a role as a bypassing device. The correct installation method is to connect a large area of the filter housing to the conductive plane of the metal housing, clear the insulating paint to ensure a reliable connection.

9. Maintenance and Inspection

9.1 Maintenance and Inspection

Due to the service environmental changes such as temperature, humidity, smoke, frost, dust, or the factors as aging of inverter's internal components, various failures of inverter may occur. Therefore, it is required to have daily check and keep regular maintenance on inverter during use and storage.

- Check if the components are broken or the screws are loose during transportation.
- Clean the inverter and periodically check if the screws are loose.
- Power-on the sleeping inverters for 30 minutes once semiannually to prevent electronic components from being disabled.
- Keep inverter away from heavy humidity and metal particles. If necessary, put it in an electric cabinet or a small room with protective measures.

Check the following items with the inverter in operation:

- The motor should not be vibrating or making unusual sound.
- Inverter and motor should not be overheating.
- The ambient temperature should not be too high.
- The output current value shown on the monitoring displays should not be higher than normal value.
- The cooling fan at the bottom of the inverter should be in normal operation.

Periodic maintenance ensures that the inverter receives the proper care to maintain overall performance. Always turn the power supply off before inspection, and the inspection starts only after LED indicator is off.

Table 9-1 Periodic Maintenances

Items	Checks	Corrective Action
Main circuit terminals, screws on control circuit terminals	Are all screws tight?	Tighten loose screws firmly.
Heatsink	Are there dirty or dusty?	Clean any dirt and dust off with an air gun using dry air at a pressure of 4~6kg/cm ²
PCBA		
Cooling fan	Is there any unusual noise or vibration or has the total operating time exceeded 20,000 hours?	Replace the cooling fan.
Power Components	Are they dusty?	Clean any dirt and dust off with an air gun using dry air at a pressure of 4~6kg/cm ²
Electrolytic Capacitor	Are there any irregularities such as discoloration or odor?	Replace the capacitor.

In order to keep the inverter operating normally over a long period of time, periodic maintenance and replacement are required for the internal parts according to their service lives. Periodic maintenance standards vary from the inverter's service environment and applications. See Table 9-2 for the part replacement guidelines.

Table 9-2 Part Replacement Guidelines

Parts	Standard Replacement Period
Cooling Fan	2~3 Years
Electrolytic Capacitor	4~5 Years
PCBA	5~8 Years

The standard replacement period is based on the following application conditions:

- Ambient temperature: 30°C (Yearly average).
- Load factor: 80% maximum
- Operation rate: 12 hours maximum per day

9.2 Outline of Warranty

SINEE will provide warranty service under following circumstances:

1. Warranty is only for inverter.
2. Authorized distributors of SINEE will take responsibilities for local services within 12 months warranty period.
3. There is a maintenance charge for any following damage occurred in 12 months.
 - Due to improper operation.
 - Due to unauthorized installation environment.
 - Due to floods, fires, or abnormal voltage fluctuations.
 - Due to the incorrect wiring.
 - Due to unauthorized modifying or altering.

Appendix A: EM100 Modbus Communication Protocol

1. Application Scope

- Applicable series: EM100
- Applicable network: Support Modbus protocol, RTU format, with single-master/multi-slave Communication network of RS485 bus.

The typical RTU message frame format:

Start Bit	Device Address	Function Code	Data	CRC	Stop Bit
T1-T2-T3-T4	8Bit	8Bit	n*8Bit	16Bit	T1-T2-T3-T4

2. Physical Interface

1. RS485 asynchronous half-duplex Communication mode. LSB has transmission priority.
2. Default data format of RS485 terminal: 1-8-N-1, bits rate: 9600bps.
3. Data format 1-8-N-1, 1-8-O-1, 1-8-E-1, optional bits rates 4800bps, 9600bps, 19200bps, and 38400bps can be selected via setting F10.01.
4. Shielded twisted-pair cable is recommended Communication cable to lower external interference.

3. Protocol Format

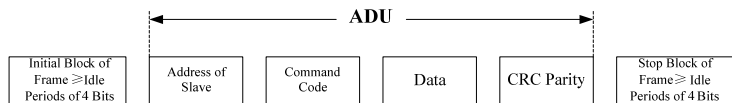

Appendix Figure 1 Protocol Format

The parity in ADU (Application Data Unit) is obtained via the CRC16 parity of the 1st three parts of ADU and switching the low bytes and high bytes. Low bytes of CRC parity go first, and high bytes of it follow in the protocol format.

4. Explanation of Command

Command code 0x03: Read parameter and status of inverter.

ADU Item	Byte No.	Range
Master requests:		
Address of slave	1	0~127
Command Code	1	0x03
Register start address	2	0x0000~0xFFFF
Register number	2	0x0000~0x0008
CRC parity(Low bytes go first)	2	
Slave responds		
Address of slave	1	Inverter address
Command code	1	0x03

Byte Length	1	2* Register number
Register data	2* Register number	
CRC parity	2	

Remarks: Read maximum 8 function codes consecutively.

Command code 0x06: Write single function code or control parameter of inverter

ADU Item	Byte No.	Range
Master requests:		
Address of slave	1	0~127
Command code	1	0x06
Register address	2	0x0000~0xFFFF
Register data	2	0x0000~0xFFFF
CRC parity	2	
Slave responds:		
Address of slave	1	Inverter address
Command code	1	0x06
Register address	2	0x0000~0xFFFF
Register data	2	0x0000~0xFFFF
CRC parity	2	

Command code 0x10: Write several function codes or control parameters of inverter

ADU Item	Byte No.	Range
Master requests:		
Address of slave	1	0~127
Command code	1	0x10
Register start address	2	0x0000~0xFFFF
Register number	2	0x0000~0x0008
Byte length of register	1	2*Register number
Register detail	2* Register number	
CRC parity	2	
Slave responds:		
Address of slave	1	Inverter address
Command code	1	0x10
Register start address	2	0x0000~0xFFFF
Register number	2	0x0000~0x0008
CRC parity	2	

Remarks: Write maximum 8 function codes consecutively

Command code 0x08: Circuit Diagnosis and Setting

ADU Item	Byte No.	Range
Master requests:		
Address of slave	1	0~127
Command code	1	0x08
Sub-function code	2	0x0000~0xFFFF
Register data	2	
CRC parity	2	
Slave responds:		
Address of slave	1	Inverter address
Command code	1	0x08
Sub-function code	2	0x0000~0xFFFF
Register data	2	
CRC parity	2	

Remarks: Command code 0x08 is only for circuit check.

5. Description of Protocol Format

5.1 Address Code

Address of slave inverter. The setting range: 1~247, 0 is broadcast address.

5.2 Command Code

Command Code	Function
03H	Read parameters and status byte of inverter
06H	Write single function code or control parameter of inverter
10H	Write several function codes or control parameters of inverter
08H	Circuit diagnosis and setting

5.3 Allocation of Register Addresses

Name	Address	Description
Function Code	0000H~1F1FH (Saving Address)	High byte is the function code group number. F00~F11, C0, E0, P0, and P1 are corresponding to high bytes: 00H~0BH, 10H, 11H, 12H, and 13H respectively. Low byte is serial number of function code group. 0~31 corresponding to low bytes 00H~1FH. For example: the corresponding saving address of F0-07 is 0007H.
	2000H~3F1FH (Temporary Saving Address)	Frequent modification of EEPROM will reduce its lifespan. Temporary saving is not required if only editing the value of function code. To avoid EEPROM damage, the address of function code+2000H. For example, the temporary saving address of F0-07 is 2007H.
Control Command	4000H	Refers to Appendix 1
Working Status	4100H	Refers to Appendix 1

5.4 CRC Parity

Sending equipment calculates CRC parity value first, and then attaches it to the sending message. Upon receipt of the message, receiving equipment will calculate CRC parity value again, and compare the operation result with received CRC parity value. If the two values are different, it indicates that there is error during transmission.

Calculation process of CRC parity:

1. Define a CRC parity register, and initialize it as FFFFH.
2. Conduct XOR calculation between the 1st byte of sending message and the value of CRC parity register, and then upload the result to CRC parity register. Start from address code, the start bit and stop bit will not be calculated.
3. Collect and check LSB (the least significant bit of CRC parity register).
4. If LSB is 1, shift each bit of CRC parity register rightwards by 1 bit, the highest bit filled with 0. Conduct XOR calculation between the value of CRC register and A001H, and then upload the result to CRC parity register.
5. If LSB is 0, shift each bit of CRC parity register rightwards by 1 bit, the highest bit filled with 0.
6. Repeat steps 3, 4 and 5 until completing 8 rounds of shifting.
7. Repeat steps 2, 3, 4, 5 and 6, and process the next byte of sending message. Repeat above process continuously until each byte of sending message is processed.
8. CRC parity data will be saved in CRC parity register after calculation.
9. LUT (Look-up table) method is to obtain CRC parity in the system with limited time resources.

Simple CRC functions as shown in following (C language Programming):

unsigned int CRC_Cal_Value(unsigned char *Data, unsigned char Length)

```
{
    unsigned int crc_value = 0xFFFF;
    int i = 0;
    while(Length--)
    {
        crc_value ^= *Data++;
        for(i=0;i<8;i++)
        {
            if(crc_value & 0x0001)
            {
                crc_value = (crc_value>>1)^ 0xa001;
            }
            else
            {
                crc_value = crc_value>>1;
            }
        }
    }
    return(crc_value);
}
```

5.5 Error Message Response

Inverter will send an error message report when the master sends error data or inverter receives the error data due to the external interference.

When Communication error occurs, slave combines the highest bit 1 of command code and error code as the response to the master.

Responding data frame format when errors happened in Communication:

ADU Item	Byte No.	Range
Error response:		
Address of slave	1	0~127
Error command code	1	The highest bit 1 of command code
Error code	1	0x01~0x13
CRC parity(Low bytes go first)	2	

Responding command code at normal Communication and error Communication

Responding Command Code at Normal Communication	Responding Command Code at Error Communication
03H	83H
06H	86H
10H	90H
08H	88H

Description of Error Code

Error Code	Description	Error Code	Description
01H	Exceptional command code	06H	Slave is busy
02H	Exceptional data address	10H	Frame error: Frame length error, parity error
03H	Exceptional data	11H	Parameter read only
04H	Slave operation failure	12H	Parameter is uneditable in operation.
05H	Command enabled, in the process	13H	Parameter is protected by password

For instance: Master sends data frame in hexadecimal format for F00.00 to write 50.00HZ frequency.

01H	06H	00H	00H	13H	88H	84H	9CH
-----	-----	-----	-----	-----	-----	-----	-----

Because F00.00 is read only, inverter responds error message. Inverter responds data frame in hexadecimal format

01H	86H	11H	82H	6CH
-----	-----	-----	-----	-----

Command code is 86H in error message, the highest bit 1 of 06H. If error code detail is 11H, it means the parameter is read only.

After responding to the error data receipt, master can revise the responding program via resending data frame or based on the error message responded by the inverter.

5.6 Details of 0x08 Circuit Diagnoses and Setting

Sub-function Code	Data Requested	Response Data	Indication of Sub-function
0000H	#data16	The same as the data requested	Circuit Diagnosis

6. Example

6.1 Read the setting value of primary numeric frequency F0-07 of inverter No.1, return 5000(50Hz).

Transmit Sequence	0	1	2	3	4	5	6	7	8	9
Data		01H	03H	20H	07H	00H	01H	3EH	0BH	

Receive Sequence	0	1	2	3	4	5	6	7	8
Data		01H	03H	02H	13H	88H	B5H	12H	

6.2 Write F0-07=30.00Hz, data transmission:3000

(The setting value of primary numeric frequency of inverter No.1)

Transmit Sequence	0	1	2	3	4	5	6	7	8	9
Data		01H	06H	00H	07H	0BH	B8H	3FH	49H	

Receive Sequence	0	1	2	3	4	5	6	7	8	9
Data		01H	06H	00H	07H	0BH	B8H	3FH	49H	

6.3 Start inverter operation, and write control command for 4000H address.

Transmit Sequence	0	1	2	3	4	5	6	7	8	9
Data		01H	06H	40H	00H	00H	01H	5DH	CAH	

Receive Sequence	0	1	2	3	4	5	6	7	8	9
Data		01H	06H	40H	00H	00H	01H	5DH	CAH	

6.4 Inverter stops

Transmit Sequence	0	1	2	3	4	5	6	7	8	9
Data		01H	06H	40H	00H	00H	05H	5CH	09H	

Receive Sequence	0	1	2	3	4	5	6	7	8	9
Data		01H	06H	40H	00H	00H	05H	5CH	09H	

Appendix Table 1

Control Command 1 (4000H)

Data	Meaning	Data	Meaning
0000H	Inactive Command	0006H	Ramp to Stop
0001H	Forward Running	0007H	Coast to Stop
0002H	Reverse Running	0008H	Fault Reset
0003H	FJOG	0009H	+/- Input Switch
0004H	RJOG	000AH	Not Used
0005H	Slave-inverter Stops	000BH	Not Used

Inverter Status 1(4100H):

Data	Meaning	Data	Meaning
0000H	Parameter Setting	0004H	Slave-inverter Stops
0001H	Slave-inverter Runs	0005H	JOG Stop
0002H	JOG Running	0006H	Fault Status
0003H	Autotuning	0007H	Factory Check

Appendix B: Accessories

1. Selecting Braking Resistor

When inverter is in the process of operation, if motor speed decreases too fast or motor load vibrates too fast, the electric potential energy of motor will charge the internal capacitor of inverter through inverter, so that inverter would be damaged due to the voltage increase of IGBT. The inverter will control such situation internally based on real load condition. An external resistor is needed for energy release when brake performance could not meet the working requirements. External braking resistor is in dynamic braking mode, and the function is to absorb the energy. Therefore, its power rating and resistance shall be selected appropriately. See the table below for selecting the braking resistor for EM100 with appropriate power rating and resistance.

Inverter Model No.	Motor Power (kW)	Resistor Resistance(Ω)	Resistor power (W)	Cable Size (mm^2)
EM100-0R4-1B	0.4	$\cong 360$	$\cong 100$	1
EM100-0R7-1B	0.75	$\cong 180$	$\cong 200$	1.5
EM100-1R5-1B	1.5	$\cong 180$	$\cong 200$	1.5
EM100-2R2-1B	2.2	$\cong 90$	$\cong 400$	2.5
EM100-0R7-1B	0.75	$\cong 360$	$\cong 200$	1
EM100-1R5-1B	1.5	$\cong 180$	$\cong 400$	1.5
EM100-2R2-1B	2.2	$\cong 180$	$\cong 400$	1.5
EM100-4R0-3B	4.0	≥ 90	≥ 800	2.5
EM100-5R5-3B	5.5	≥ 60	≥ 1000	4
EM100-7R5-3B	7.5	≥ 60	≥ 1000	4
EM100-011-3B	11	≥ 30	≥ 2000	6
EM100-015-3B	15	≥ 30	≥ 2000	6

Remarks:

Cables listed in above table refer to the lead cable of single resistor. The DC bus should be uprated if the resistors are in parallel connection. Cable should withstand voltage above AC300V when connecting to 1-phase inverter, or above \geq AC450V when connecting to 3-phase inverter, and temperature resistance of cable: 105°C. Because

there is a resistor limit of power consumption, the longest operation time for 10%ED is 10S (On:10S/ Off:90S).

2. Optional Installation Accessories

No.	Item	References	Product Code No.
1	Keypad Chassis	See 2.6.3 for detail	63200129
2	Mounting Flanges(SIZE3)	See 3.1.7 for detail	63240109
3	Mounting Flanges(SIZE4)	See 3.1.7 for detail	63240106